

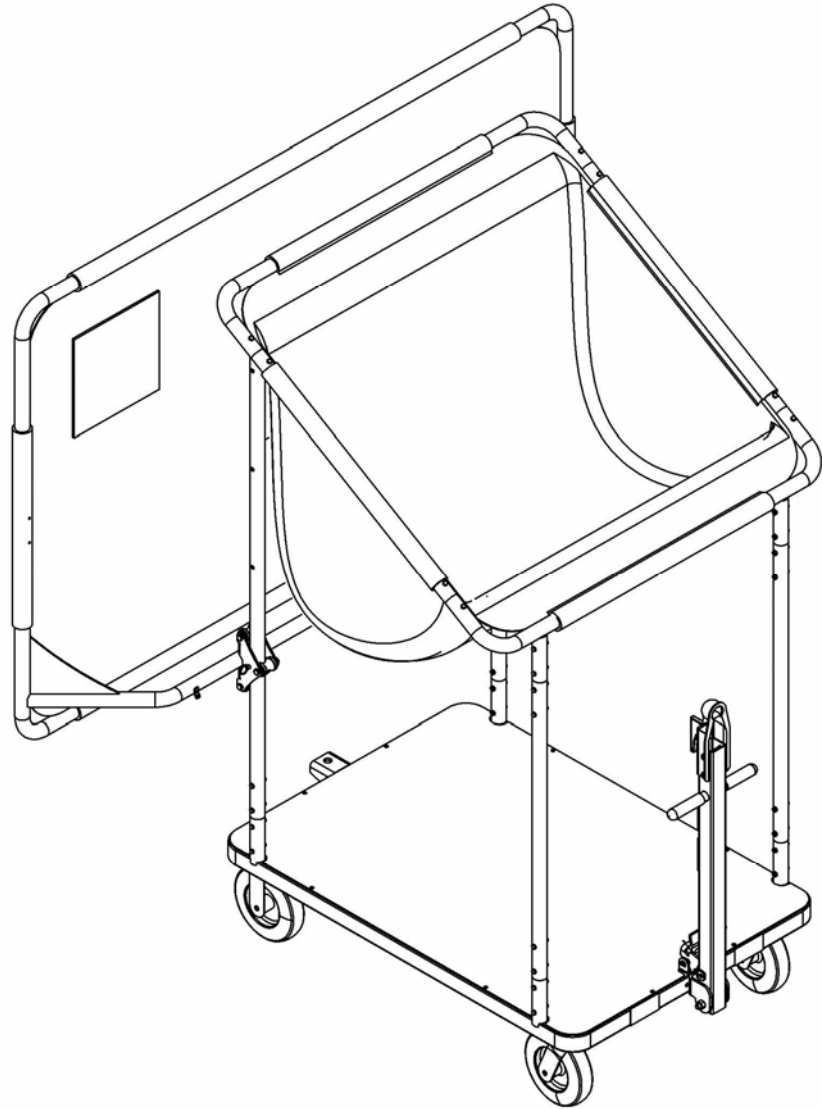

ROGERS
For the Perfection of Football Fundamentals™

PRODUCT INFORMATION PACKET
PRODUCT NAME: COMBO PASSING TRAINER
PRODUCT PART NUMBER: 410621



KEEP INFORMATION PACKET FOR FUTURE REFERENCE

TABLE OF CONTENTS

- Introduction.....1
- General Safety Rules.....2
- Symbols.....3
- Technical Specifications.....4
- Assembly Instructions.....5-10
- Maintenance.....11
- Customer Service Information.....11

INTRODUCTION

The Rogers Athletic Combo Passing Trainer has been designed and manufactured with safety, performance and dependability as top priorities, making it easy to operate and maintain.

The care you give your Combo Passing Trainer will greatly determine your satisfaction with its performance and service life. Careful study of this manual is encouraged to obtain a thorough understanding of your new Combo Passing Trainer and its functions.

If your manual is lost or destroyed, Rogers Athletic will gladly provide you with a new copy. Should you require additional information or assistance, please feel free to contact us at 800-457-5337.

BECAUSE ROGERS ATHLETIC MAINTAINS AN ONGOING PROGRAM OF
PRODUCT DEVELOPMENT AND IMPROVEMENT, WE RESERVE THE
RIGHT TO MAKE IMPROVEMENTS IN DESIGN OR CHANGES IN
SPECIFICATIONS WITHOUT INCURRING ANY OBLIGATIONS TO INSTALL
THEM ON UNITS PREVIOUSLY SOLD.

GENERAL SAFETY RULES



WARNING!































READ AND UNDERSTAND ALL INSTRUCTIONS.

Failure to follow all instructions listed below may result in serious personal injury.

SAVE THESE INSTRUCTIONS

- **Supervision of athletes while using the equipment is recommended.** Horse play such as climbing on the machine or using the machine for unintended purpose can result in injuries.
- **Athletes should be oriented in the proper use of the equipment.** Beware of pinch points.
- **Athletes should be properly fit to engage in a workout regimen.** Obtaining a medical exam prior to beginning any training program is recommended. If an athlete feels faint, dizzy, or experiences pain at any time while exercising, they should stop exercising and consult a physician.
- **Inspect equipment prior to use.** DO NOT use if it appears damaged or inoperable.
- **This Product Information Packet is an integral part of this machine.** Save these instructions. If they are lost or damaged or if you would like another copy, a copy can be downloaded from www.RogersAthletic.com
- **Reading the Product Information Packet is recommended.** Failure to read this Packet is considered a misuse of this equipment.
- **Warning labels are an integral part of this equipment.** Become familiar with all caution/warning labels and never cover or deface caution/warning labels.
- **Deploy the equipment allowing sufficient room for safe access to the machine, adequate room for the coaches to stand and to ensure that the machine or players do not collide with a wall, another machine, or other players through the entire training exercise.**
- **When not in use, store this equipment in a secure controlled area.** Unsupervised and/or inappropriate use of this equipment could result in serious injury.
- **Make sure the hitch coupler is properly engaged before towing Passing Trainer.**
- **The Passing Trainer is for Off Road use only.** The cart is intended to be used at practice/game fields. Do not attempt to tow cart on main road ways.
- **Do not tow Passing Trainer at speeds exceeding 5 mph.** Towing at excessive speeds may cause the cart to lose control thereby causing an accident or serious injury. Target net should be placed in its lowest position before towing.
- **Do not ride on the Passing Trainer.** The cart was not designed to haul objects. Failure to adhere by this rule can cause serious personal injury.
- **Set brakes on the Passing Trainer when left unattended.**

SYMBOLS

	<p>Safety Alert: Precautions that involve your safety</p>				
<table border="1" data-bbox="191 407 574 638"> <tr> <th colspan="2" data-bbox="191 407 574 449">  WARNING </th> </tr> <tr> <td data-bbox="191 449 363 638">  </td> <td data-bbox="363 449 574 638"> <p>Store in secure area. Inappropriate use of this equipment could result in serious injury.</p> </td> </tr> </table>	 WARNING			<p>Store in secure area. Inappropriate use of this equipment could result in serious injury.</p>	<p>Store this equipment in a secure, controlled area: Unsupervised and/or inappropriate use of this equipment could result in serious injury.</p>
 WARNING					
	<p>Store in secure area. Inappropriate use of this equipment could result in serious injury.</p>				
<table border="1" data-bbox="191 688 574 877"> <tr> <th colspan="2" data-bbox="191 688 574 739">  CAUTION </th> </tr> <tr> <td data-bbox="191 739 363 877">  </td> <td data-bbox="363 739 574 877"> <p>Pinch Point. Keep Hands And Fingers Clear</p> </td> </tr> </table>	 CAUTION			<p>Pinch Point. Keep Hands And Fingers Clear</p>	<p>Pinch Point Warning Label: Failure to keep hands away from pinch points will result in personal injury</p>
 CAUTION					
	<p>Pinch Point. Keep Hands And Fingers Clear</p>				
<table border="1" data-bbox="191 940 574 1117"> <tr> <th colspan="2" data-bbox="191 940 574 991">  CAUTION </th> </tr> <tr> <td data-bbox="191 991 363 1117">  </td> <td data-bbox="363 991 574 1117"> <p>Avoid Injury. Do not climb.</p> </td> </tr> </table>	 CAUTION			<p>Avoid Injury. Do not climb.</p>	<p>Do Not Climb Warning Label: To reduce risk of injury, do not climb on field equipment</p>
 CAUTION					
	<p>Avoid Injury. Do not climb.</p>				
<table border="1" data-bbox="191 1184 574 1369"> <tr> <th colspan="2" data-bbox="191 1184 574 1234">  CAUTION </th> </tr> <tr> <td data-bbox="191 1234 363 1369">  </td> <td data-bbox="363 1234 574 1369"> <p>Off-Road Use Only</p> </td> </tr> </table>	 CAUTION			<p>Off-Road Use Only</p>	<p>For Off-Road Use Only Warning Label: Field equipment is not intended or designated for roadway travel</p>
 CAUTION					
	<p>Off-Road Use Only</p>				
<table border="1" data-bbox="191 1444 574 1633"> <tr> <th colspan="2" data-bbox="191 1444 574 1495">  CAUTION </th> </tr> <tr> <td data-bbox="191 1495 363 1633">  </td> <td data-bbox="363 1495 574 1633"> <p>Do Not Exceed 5 mph</p> </td> </tr> </table>	 CAUTION			<p>Do Not Exceed 5 mph</p>	<p>Hauling Speed Warning Label: Do not exceed 5 mph when hauling field equipment.</p>
 CAUTION					
	<p>Do Not Exceed 5 mph</p>				

ROGERS ATHLETIC FIELD EQUIPMENT SPECIFICATIONS

COMBO PASSING TRAINER (PART #410621)

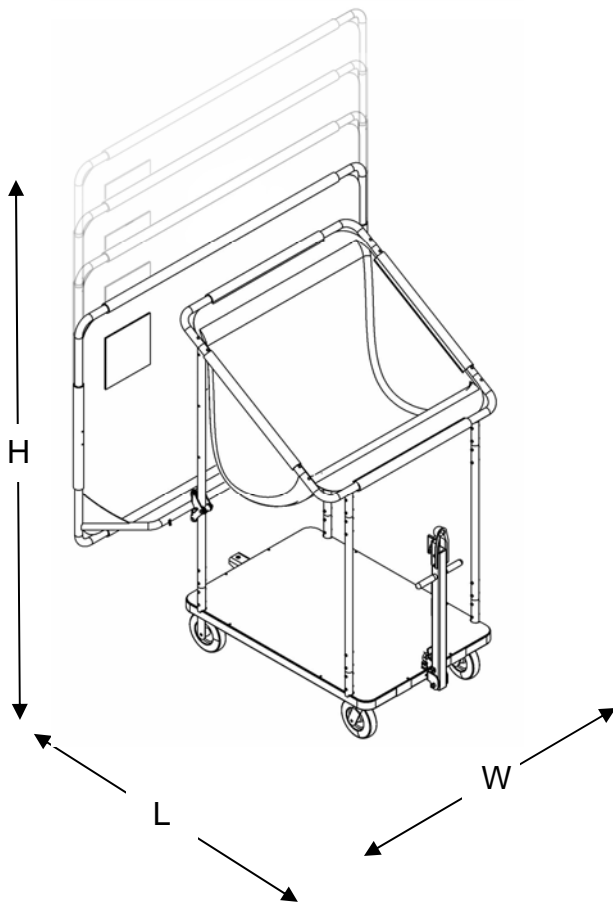

Weight: 200 lbs	(91 kg)
Height: 84 – 120 in	(213 - 305 cm)
Length: 60 in	(152 cm)
Width: 78 in	(198 cm)

- Combo Passing Trainer allows users to work independently on multiple passing techniques
- Height of target net can be adjusted to 7, 8, 9 or 10 ft in order to work on QB accuracy and high release
- Target net can also be used by long snappers to work on accuracy and by kickers to learn to get the ball up in the air
- Teach QBs to throw a high trajectory touch pass to the corner of the end zone with the drop-in net
- Four – eight inch foam filled casters for ease of transportation over the roughest terrain
- User friendly hitch locking mechanism allows for quick and easy positioning of hitch tube, multiple carts can be easily connected together for a rapid, more efficient deployment
- Cart can be moved manually or with a hitched vehicle
- Full floor for transporting balls, practice equipment and other training gear

Construction, Finish and Hardware

- Constructed of ASTM specified steel.
- 6061 – T4 Aluminum.
- Baked-on powder coat finish.
- GripWorks® “Softex” grip material or equivalent.
- Non-marking foam filled locking casters.
- Zinc-plated hardware Grade 5 or equivalent.

Assembly Instructions

1

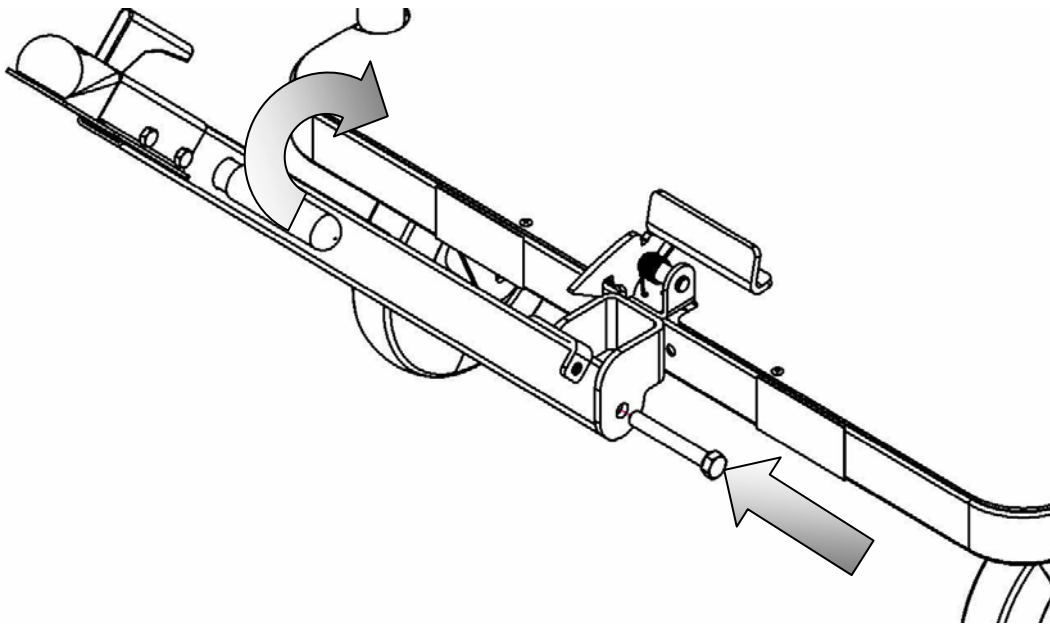

Align the hole in the hitch tube with the hole in the mount bracket. Insert the 1/2" x 3 1/2" bolt thru the bracket and turn the 1/2" lock nut onto the threads. Use two 3/4" wrenches to tighten the bolt. With the bolt fully tightened rotate the hitch tube to its vertical storage position. To release the hitch tube for maneuvering or towing use your foot to depress the hitch lock and rotate the hitch tube to the desired position.

2

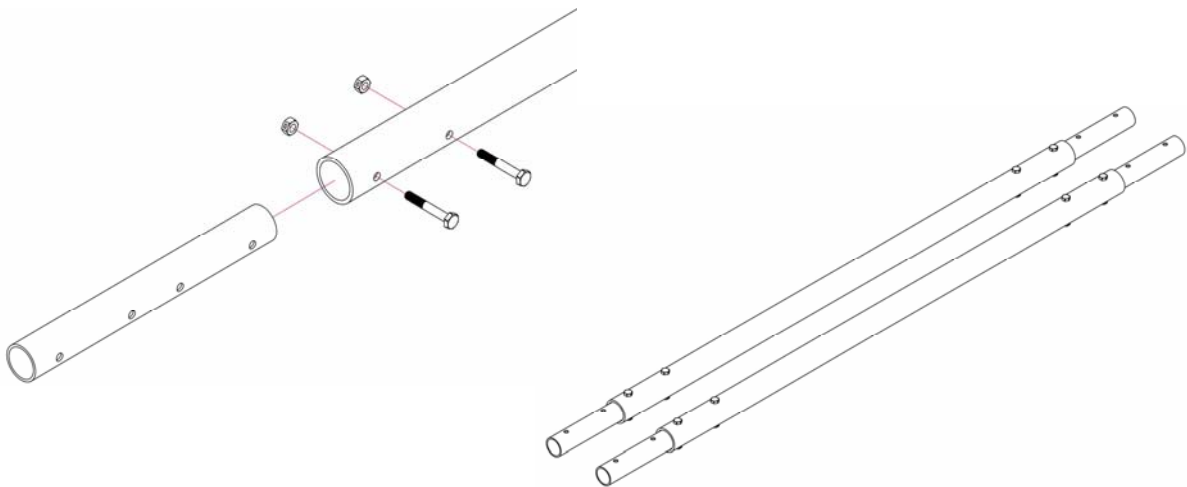

Assemble (2) front vertical tubes by aligning the holes of (4) inserts to the holes in the vertical tubes. With the holes aligned use (2) 1/4" x 1 3/4" bolts and (2) 1/4" lock nuts per insert to secure their position. *Do not fully tighten the bolts at this time.*

3

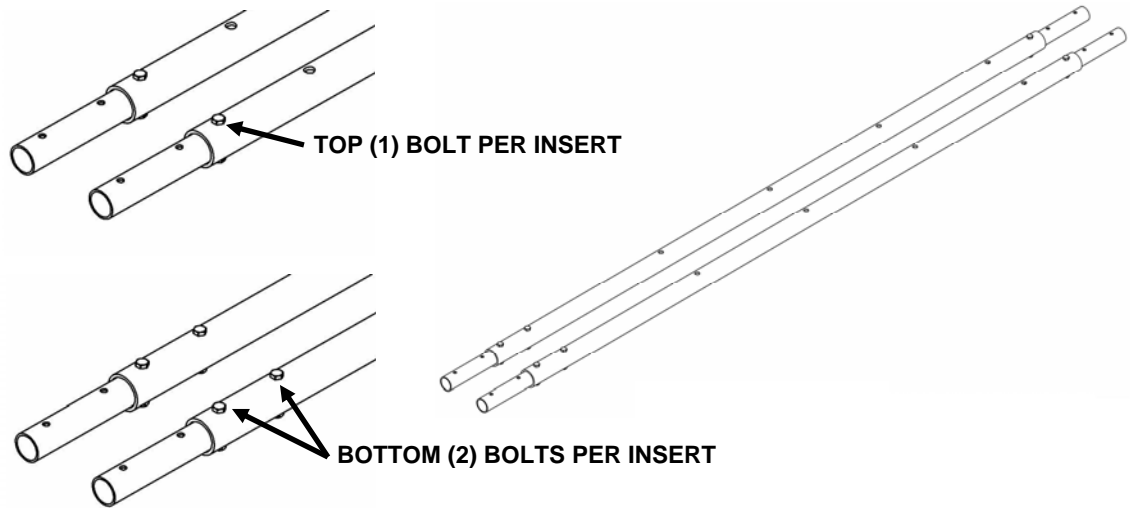

Assemble (2) rear vertical tubes by aligning the holes of (4) inserts to the holes in the vertical tubes. The inserts placed at the bottom of the vertical tube will be fastened with (2) 1/4" x 1 3/4" bolts and (2) 1/4" lock nuts per insert. The inserts placed at the top of the tube will only be fastened with (1) bolt and (1) nut per insert. *Do not fully tighten the bolts at this time.*

4

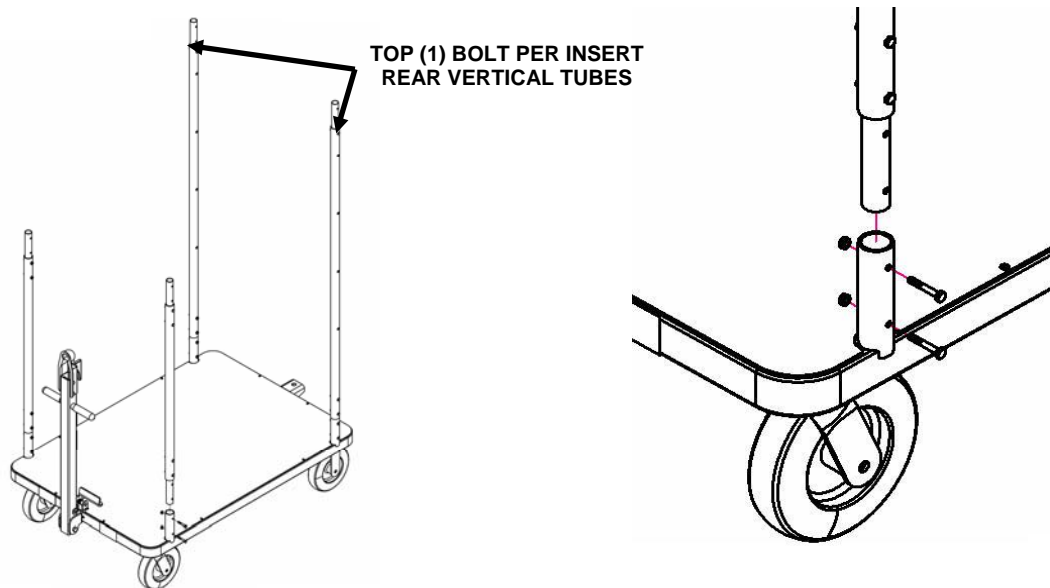

Use (8) 1/4" x 1 3/4" bolts and (8) 1/4" lock nuts to secure vertical tubes to cart frame, do not fully tighten bolts at this time. Make sure rear vertical tubes are oriented properly as described in Step #3.

5

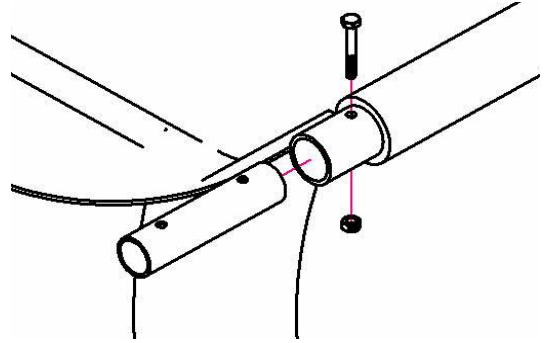
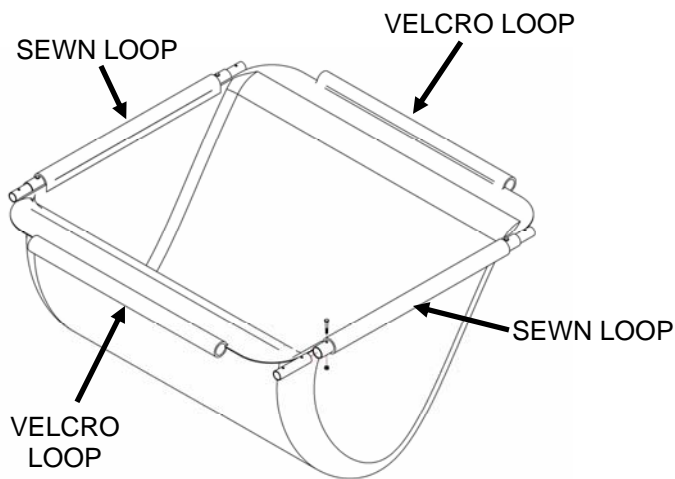

Begin assembly of the drop – in net by pushing the connection tubes thru the **sewn** vinyl loops on the sides of the net. With connection tubes in position place short insert tubes into each end of the connection tubes. Use (1) 1/4" x 1 3/4" bolt and (1) 1/4" lock nut per insert to hold position. *Do not fully tighten at this time.*

6

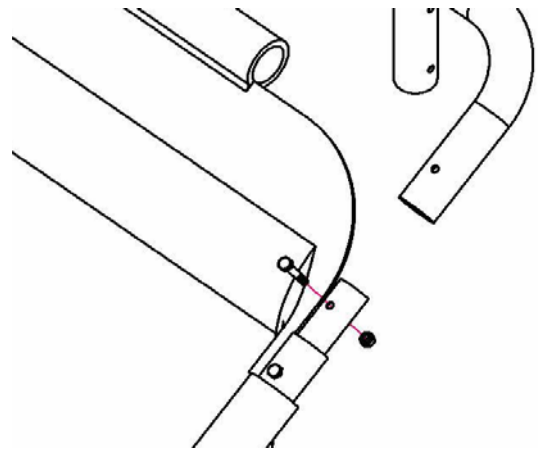
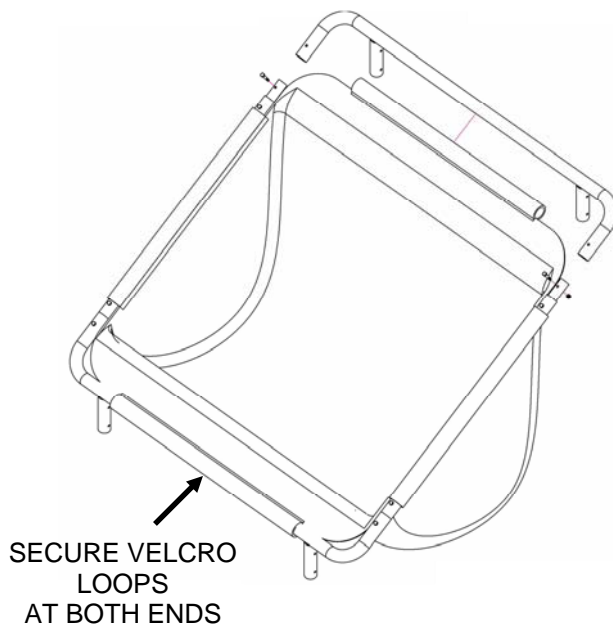

Finish assembly of the drop – in net by connecting the side pieces to the connection tubes. Secure connections with 1/4" x 1 3/4" bolts and 1/4" lock nuts. Fully tighten all (8) bolts at this time, this will require two 7/16" wrenches. Complete net assembly by securing Velcro loops around the side tubes.

7

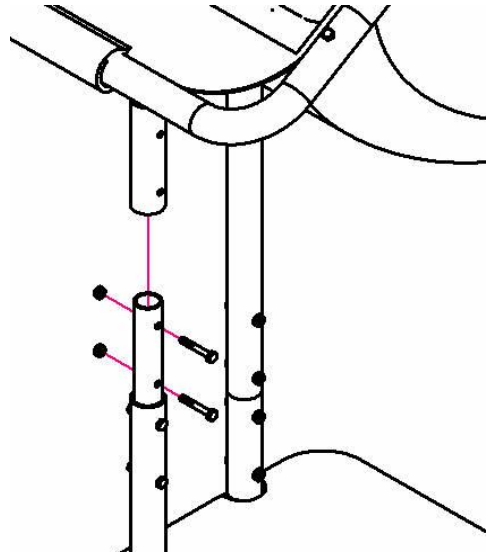
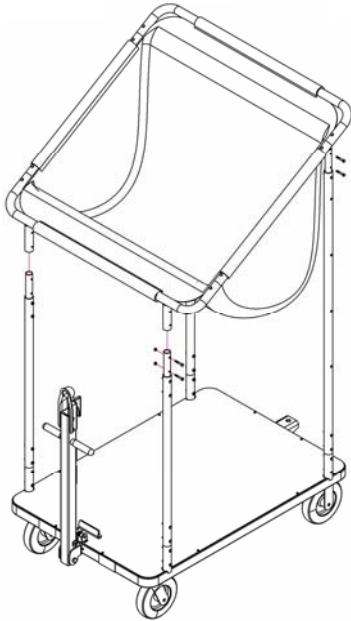

Position the drop – in net assembly over top of the vertical tubes. Align the tubes in each corner and lower the net assembly onto the vertical tubes. Each corner connection gets secured with (2) 1/4" x 1 3/4" bolts and (2) 1/4" lock nuts. Use two 7/16" wrenches to fully tighten any loose bolts at this time. **Note: This step requires two people.**

8

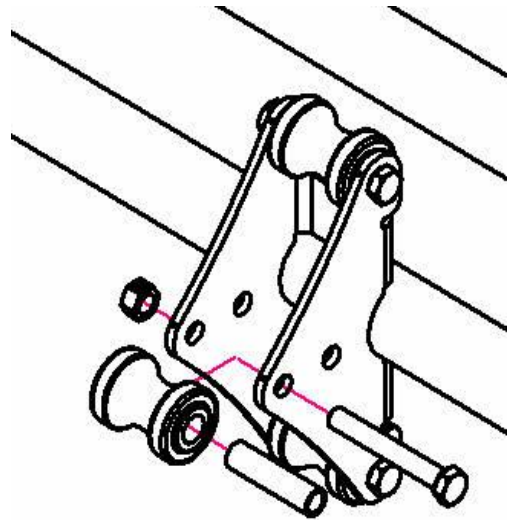
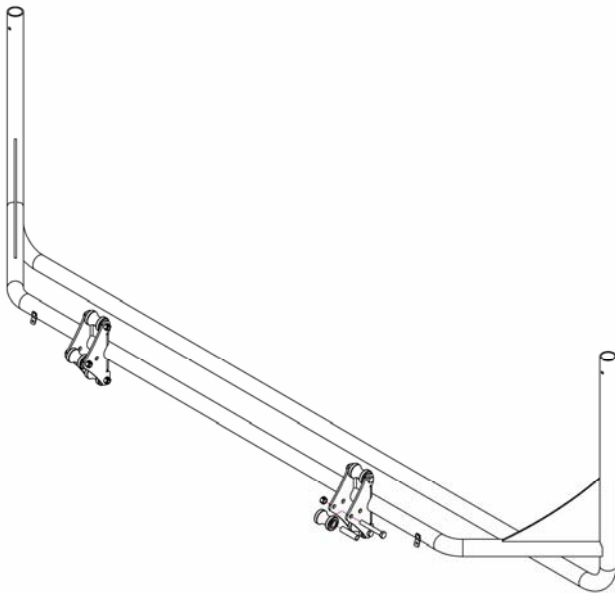

Begin assembly of the target net by installing the (6) rollers onto the bottom portion of the net frame. Insert a bushing tube thru each roller and then align the roller with the holes in the mounting bracket. Secure each roller with (1) 3/8" x 2 3/4" bolt and (1) 3/8" lock nut. Use two 9/16" wrenches to tighten.

9

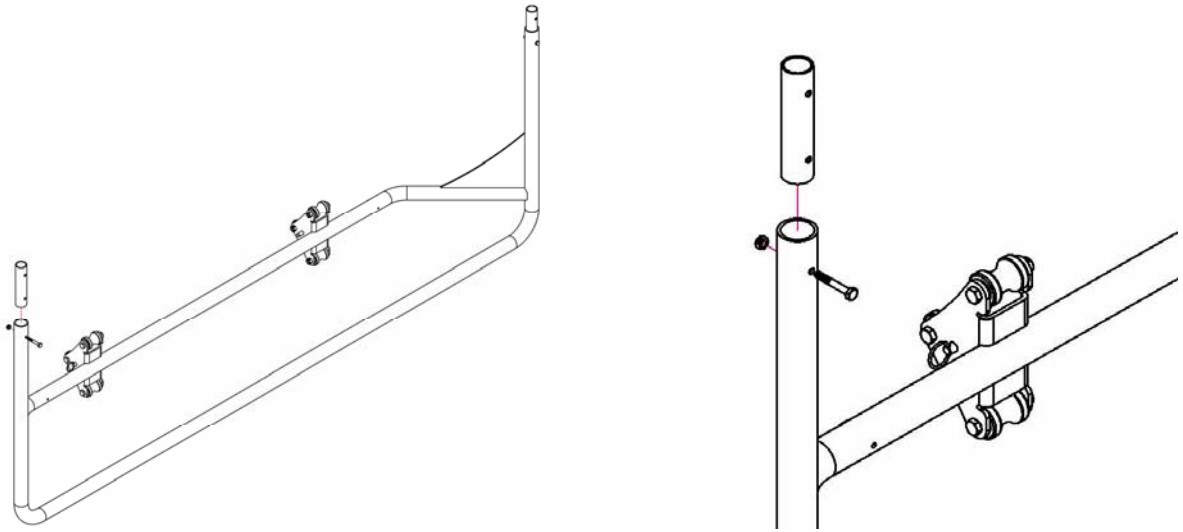

Insert connection tubes into the bottom portion of the target net frame and secure their position with (1) 1/4" x 1 3/4" bolt and (1) 1/4" lock nut per tube.

10

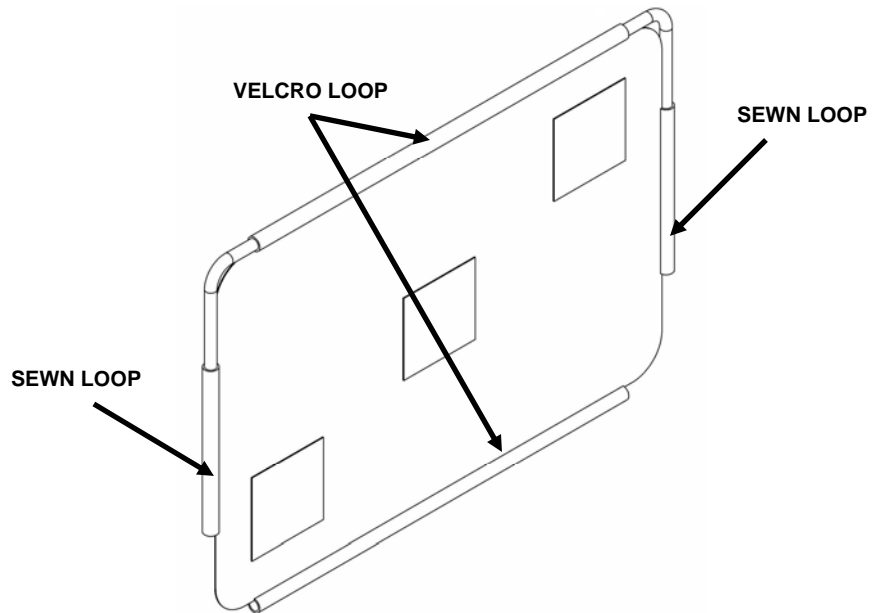

Align the top frame tube to the sewn loops in the target net. Insert the side tubes thru the sewn loops and then loosely attach the top Velcro loop.

11

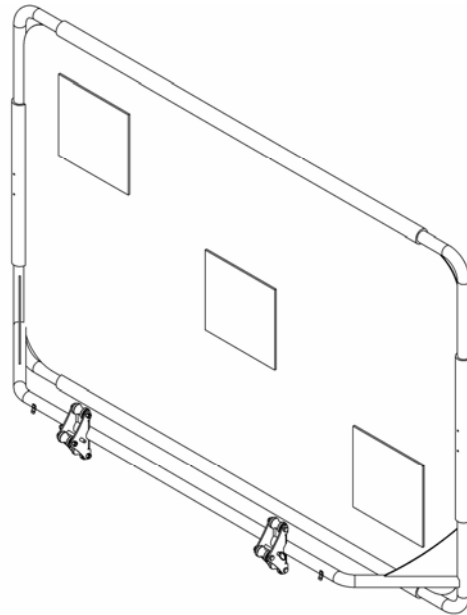

Finish assembly of the target net by aligning the top frame to the bottom frame. Secure top frame to the connection tubes with (2) 1/4" x 1 3/4" bolts and (2) 1/4" lock nuts. Attach top and bottom Velcro loops as well as all four corner loops. Make sure all bolts are fully tightened.

12

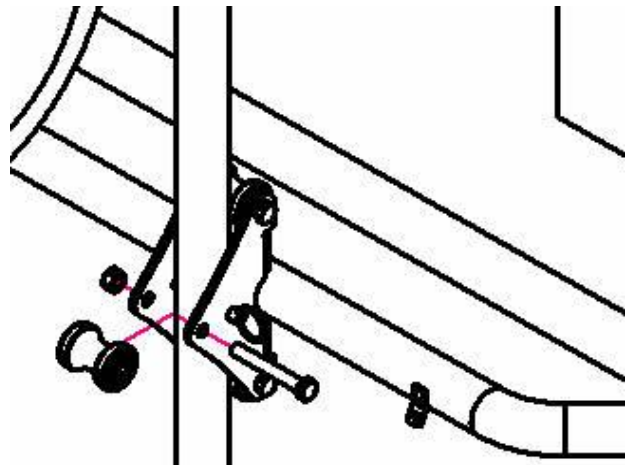
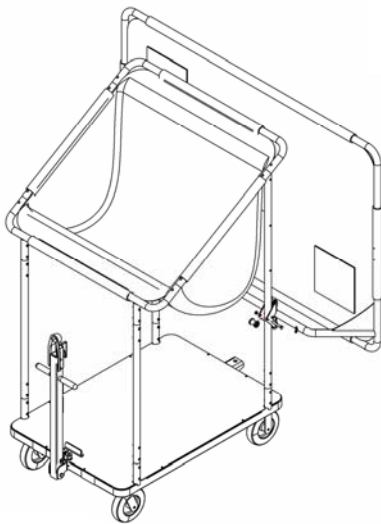

With both front rollers removed from the target net assembly, position the target net onto the rear vertical tubes of the cart. Reassemble the front rollers onto the target net assembly. Adjust target net to the desired height and secure its position by inserting the pins thru the roller bracket and vertical tube. **Note: This step requires two people.**

MAINTENANCE



WARNING!

READ AND UNDERSTAND ALL MAINTENANCE PROCEDURES.

Failure to follow all procedures listed below may cause serious injury and a decrease in the equipments functional existence.

- **Frequently check to see that all bolts are securely fastened.**
- **Field equipment should be washed periodically with soapy water to maintain original surface finish.**
- **Frequently check trailer hitch coupler for proper locking.** Failure to do so could result in serious injury or accident.
- **Touch up paint can be used to cover any scratches or blemishes sustained through use.**
- **A silicone based lubricant may be used on moving parts to maintain proper function.**
- **Replace any damaged equipment with genuine Rogers Athletic parts.** Failure to do so may result in unsafe equipment and/or personal injury.

CUSTOMER SERVICE

For parts or service contact Rogers Athletic Company. When ordering parts be sure to provide all relevant information available including the name and part number of the equipment purchased. This information is located on the cover of this product information package. Customer service hours are Monday through Friday from 8:00 a.m. to 5:00 p.m. Eastern Standard Time. Customers can phone (989) 386-2950 or toll free at 1-800-457-5337. Fax toll free at (888) 549-9659 or mail:

Rogers Athletic Company
3760 West Ludington Drive
Farwell, Michigan 48622

Rogers Athletic Company
3760 West Ludington Drive
Farwell, MI 48622
www.rogersathletic.com
(989) 386-2950
(800) 457-5337
Fax toll free (888) 549-9659