



# ROGGIERS

*For the Perfection of Football Fundamentals™*

## PRODUCT INFORMATION PACKET

PRODUCT NAME: GAME DAY TRAILER

PRODUCT PART NUMBER: 410551

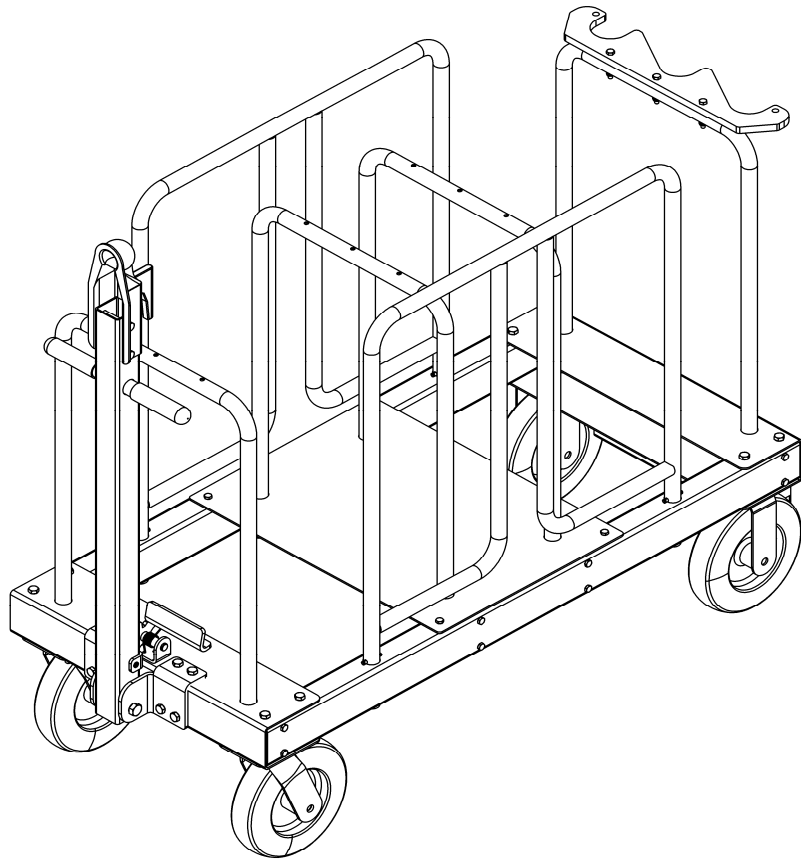

**KEEP INFORMATION PACKET FOR FUTURE REFERENCE**

# TABLE OF CONTENTS

---

- Introduction.....1
- General Safety Rules.....2
- Symbols.....3
- Technical Specifications.....4
- Use Instructions.....5
- Maintenance.....8
- Customer Service Information.....8

## INTRODUCTION

---

The Rogers Athletic Game Day Trailer has been designed and manufactured with safety, performance, and dependability as top priorities, making it easy to operate and maintain.

The care you give your Game Day Trailer will greatly determine your satisfaction with its performance and service life. Careful study of this manual is encouraged to obtain a thorough understanding of your new Game Day Trailer and its functions and maintenance.

If your manual should become lost or destroyed, Rogers Athletics will gladly provide you with a new copy. Should you require additional information or assistance, please feel free to contact us 1-800-457-5337.

BECAUSE ROGERS ATHLETICS MAINTAINS AN ONGOING PROGRAM OF  
PRODUCT DEVELOPMENT AND IMPROVEMENT, WE RESERVE THE RIGHT  
TO MAKE IMPROVEMENTS IN DESIGN OR CHANGES IN SPECIFICATIONS  
WITHOUT INCURRING ANY OBLIGATIONS TO INSTALL THEM ON UNITS  
PREVIOUSLY SOLD.

# GENERAL SAFETY RULES

---



## **WARNING!**

### **READ AND UNDERSTAND ALL INSTRUCTIONS.**





Failure to follow all instructions listed below may result in serious personal injury.

---

## **SAVE THESE INSTRUCTIONS**

- **Supervision of athletes while using the equipment is recommended.** Horse play such as climbing on the machine or using the machine for unintended purpose can result in injuries.
- **Inspect equipment prior to use.** DO NOT use if it appears damaged or inoperable.
- **This Product Information Packet is an integral part of this machine.** Save these instructions. If they are lost or damaged or if you would like another copy, a copy can be downloaded from [www.RogersAthletic.com](http://www.RogersAthletic.com)
- **Reading the Product Information Packet is recommended.** Failure to read this Packet is considered a misuse of this equipment.
- **Warning labels are an integral part of this equipment.** Become familiar with all caution/warning labels and never cover or deface caution/warning labels. Stay clear of all pinch points.
- **When not in use, store this equipment in a secure controlled area.** Unsupervised and/or inappropriate use of this equipment could result in serious injury.
- **The Game Day Trailer is for Off Road use only.** The trailer is intended to be used at practice/game fields. Do not attempt to haul trailer on main road ways.
- **Do not haul Game Day Trailer at speeds exceeding 5 mph.** Hauling at excessive speed may cause the trailer to lose control thereby causing an accident or serious injury.
- **Do not ride on the Game Day Trailer.** The trailer is intended to haul equipment only. Failure to adhere by this rule can cause serious personal injury.
- **Do not climb on the Game Day Trailer.** The trailer is not a toy and should not be played on.
- **Set brakes on the Game Day Trailer when left unattended.**
- **Save these instructions.** Refer to them frequently and use them to instruct others who may use the Game Day Trailer. If you loan someone this trailer, loan them these instructions also.
- **Become familiar with all caution and warning decals affixed to the field equipment before use.**
- **Never cover or deface caution/warning labels.**

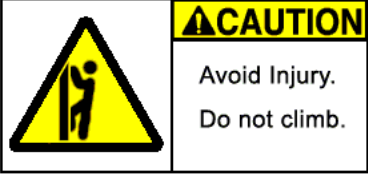
# SYMBOLS

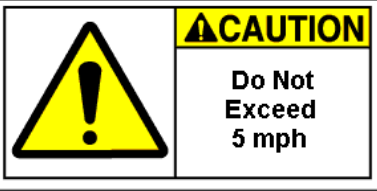
	<p><b>Safety Alert:</b> Precautions that involve your safety</p>
	<p><b>Store this equipment in a secure, controlled area:</b> Unsupervised and/or inappropriate use of this equipment could result in serious injury.</p>
	<p><b>Pinch Point Symbol:</b> Failure to keep hands away from pinch points will result in personal injury</p>
	<p><b>Do Not Climb Warning Label:</b> To reduce risk of injury, do not climb on field equipment</p>
	<p><b>For Off-Road Use Only Warning Label:</b> Field equipment is not intended or designated for roadway travel</p>
	<p><b>Hauling Speed Warning Label:</b> Do not exceed 5 mph when hauling field equipment.</p>

# ROGERS ATHLETIC GAME DAY TRAILER SPECIFICATIONS

## GAME DAY TRAILER (PART# 410551)

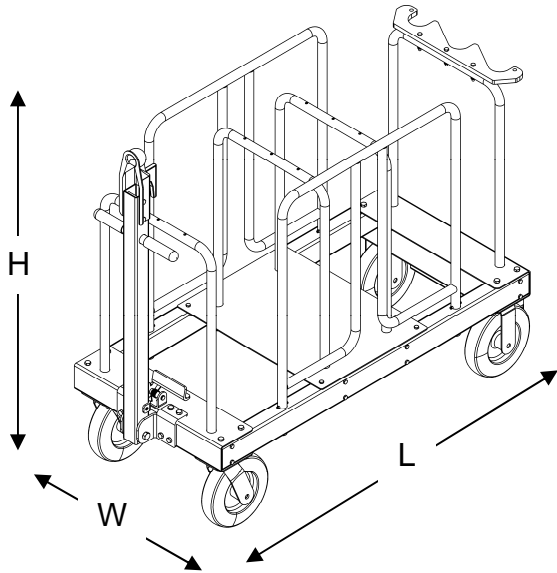

Weight:	161 lbs (72 kg)
Height:	44" (112 cm)
Length:	52" (132 cm)
Width:	22" each (56 cm)

- Designed to carry a combination of yard line markers, pylon markers, chain markers and down markers.
- Removable marker rails for ease of stacking yard line markers and pylon markers.
- Chain markers and down markers held securely in place with the marker holder and pole mount.
- User friendly hitch tube locking mechanism allows for quick and easy positioning of the hitch tube.
- GripWorks® "Softex" grips on handles for greater grip and comfort.
- Four-eight inch pneumatic casters for ease of transportation over the roughest terrain.
- Trailer can be maneuvered manually or with a hitched vehicle.

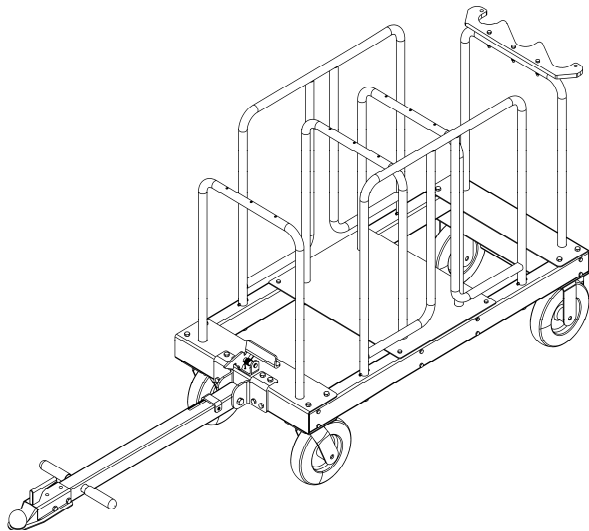

## Cart Construction, Finish, and Hardware

- Construction of ASTM specified steel.
- Baked-on powder coat finish.
- GripWorks® "Softex" grip material or equivalent.
- Non-marking pneumatic casters.
- Zinc-plated hardware.
- Polyurea coated hitch latch

1

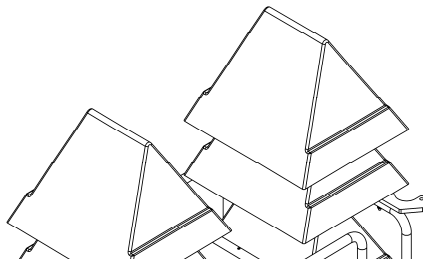

Engage the caster brakes once cart is positioned. Begin by stacking yard line markers into the Game Day Trailer. The marker rails can be taken off of the trailer in order to make this process easier if so desired (see Step 6)

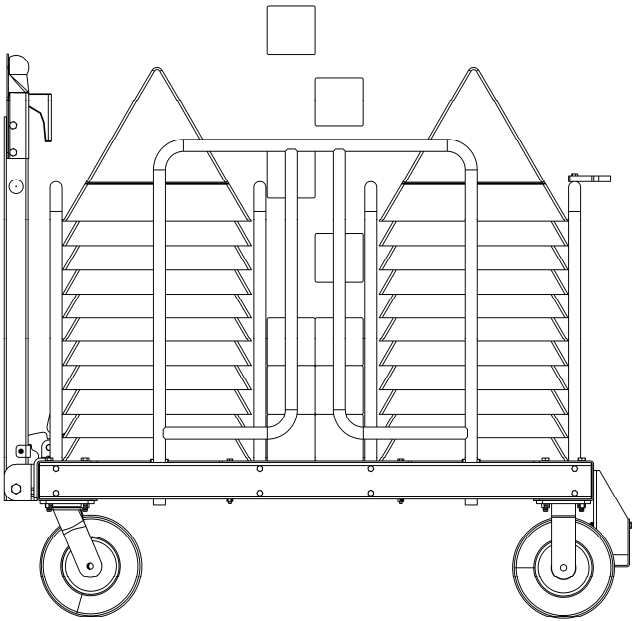

Place the pylon markers into the trailer between the yard line markers. If desired, the marker rails can be taken off of the trailer in order to make this process easier.

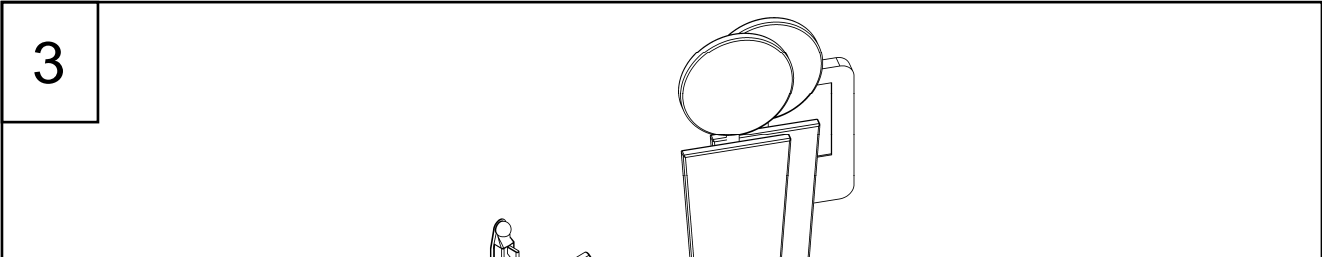

Place the chain markers and down marker into the pole mount and secure them to the marker holder with a bungee strap. Replace marker rails if previously removed.

4

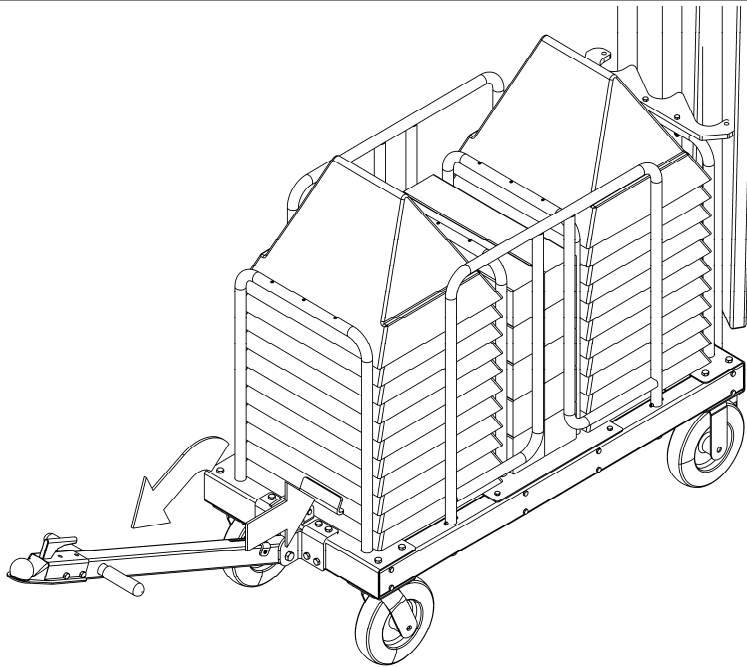

To unlock the hitch from the upright/locked position, disengage the locking mechanism by depressing the hitch latch. This allows the hitch tube to lower to its hauling position so it can be moved manually or with a hitched vehicle. Hitch has handles for manual pulling.

5

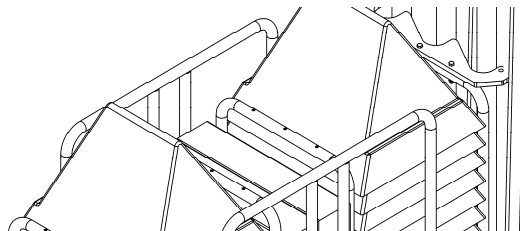

Raising the hitch tube back up will cause it to automatically lock in the upright position for storage.

6

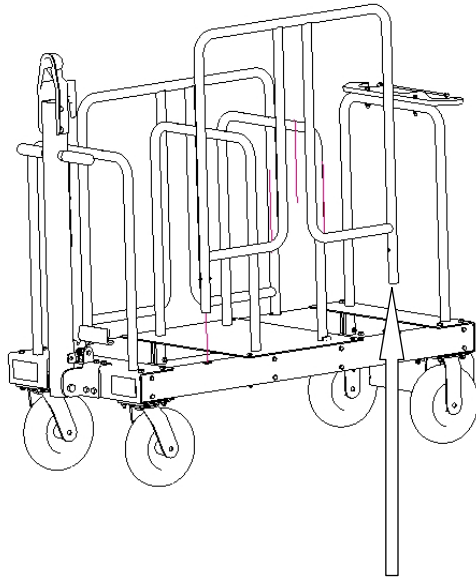

To remove marker rails, lift rails upward out of base.

## MAINTENANCE



## **WARNING!**

### **READ AND UNDERSTAND ALL MAINTENANCE PROCEDURES.**

Failure to follow all procedures listed below may cause serious injury and a decrease in the equipments functional existence.

---

- **Check and maintain air pressure in tires monthly.** Failure to do so could result in improper handling of the field equipment thus causing an accident or serious injury. Reference tire side wall for recommended air pressure.
- **Frequently check to see that all bolts are securely fastened.**
- **Field equipment should be washed periodically with soapy water to maintain original surface finish.**
- **Frequently check trailer hitch coupler for proper locking.** Failure to do so could result in serious injury or accident.
- **Touch up paint can be used to cover any scratches or blemishes sustained through use.**
- **A silicone based lubricant may be used on moving parts to maintain proper function.**
- **Replace any damaged equipment with genuine Rogers Athletic parts.** Failure to do so may result in unsafe equipment and/or personal injury.

## **CUSTOMER SERVICE**

---

For parts or service, contact Rogers Athletic Company. When ordering parts be sure to provide all relevant information available including the name and part number of the equipment purchased. This information is located on the cover of this product information packet. Customer Service hours are Monday through Friday from 8:00 a.m. to 5:00 p.m. Eastern Standard Time. Customers can phone (989) 386-2950 or toll free at 1-800-457-5337. Fax toll free at (888) 549-9659 or mail:

Rogers Athletic Company  
3760 W. Ludington Drive  
Farwell, Michigan 48622

Rogers Athletic Company  
3760 N. Ludington Drive  
Farwell, MI 48622  
[www.rogersathletic.com](http://www.rogersathletic.com)  
(989) 386-2950  
(800) 457-5337  
Fax toll free (888) 549-965

PIP410551