

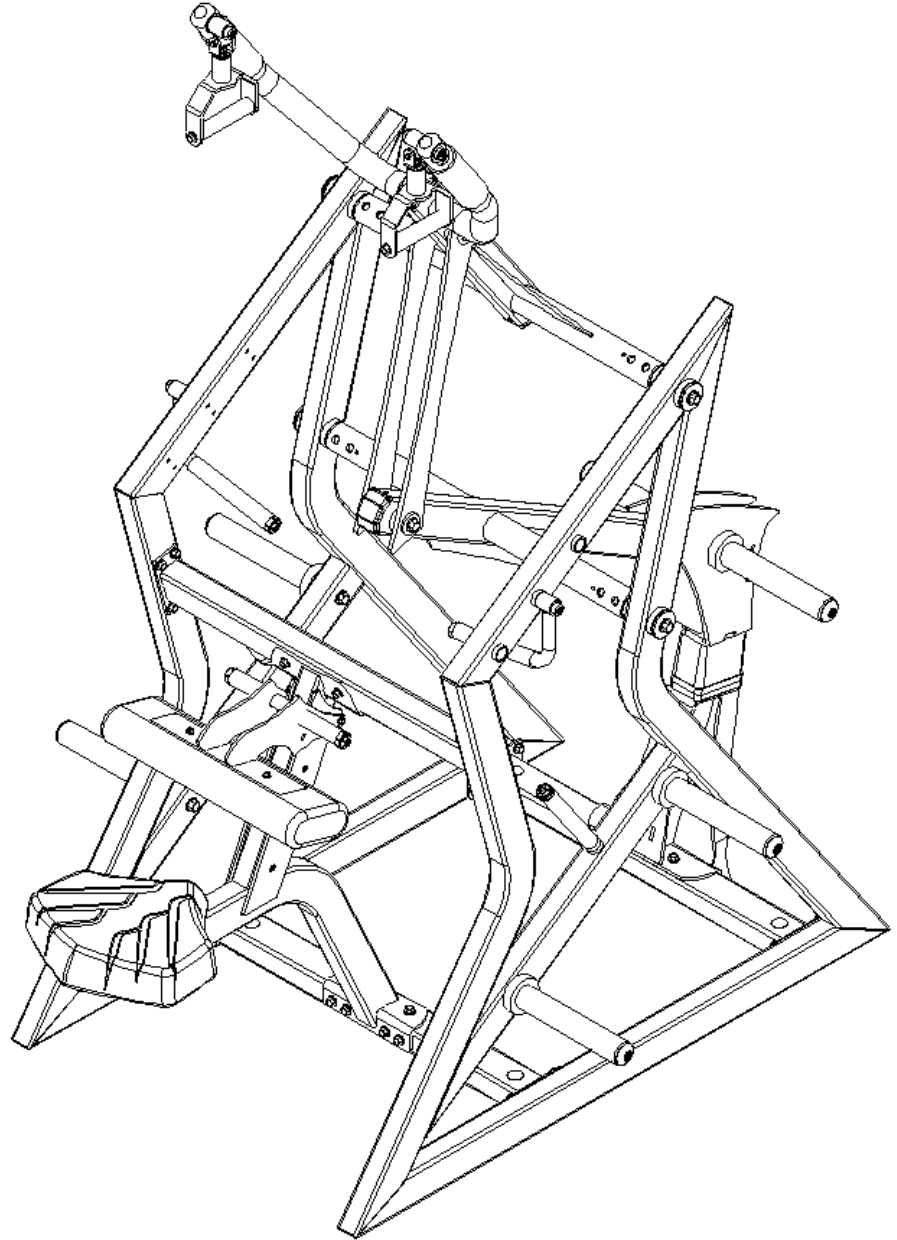

# ROGERS

PRODUCT INFORMATION PACKET  
PENDULUM LAT COMBO PULL MACHINE  
PRODUCT PART NUMBER: 410604



KEEP INFORMATION PACKET FOR FUTURE REFERENCE

# TABLE OF CONTENTS

---

- Introduction.....1
- General Safety Rules.....2
- Symbols.....4
- Technical Specifications.....5
- User Instructions.....6
- Maintenance.....8
- Customer Service Information.....9

## INTRODUCTION

---

The Rogers Athletic Pendulum Lat Combo Pull Machine has been designed and manufactured with safety, performance and dependability as top priorities, as well as making it easy to operate and maintain.

The care you give your Pendulum Lat Machine will greatly determine your satisfaction with its performance and service life. Careful study of this manual is encouraged to obtain a thorough understanding of your new Pendulum Lat Machine and its functions.

If your manual is lost or destroyed, Rogers Athletic will gladly provide you with a new copy. Should you require additional information or assistance, please feel free to contact us at 800-457-5337.

BECAUSE ROGERS ATHLETICS MAINTAINS AN ONGOING PROGRAM OF  
PRODUCT DEVELOPMENT AND IMPROVEMENT, WE RESERVE THE  
RIGHT TO MAKE IMPROVEMENTS IN DESIGN OR CHANGES IN  
SPECIFICATIONS WITHOUT INCURRING ANY OBLIGATIONS TO INSTALL  
THEM ON UNITS PREVIOUSLY SOLD.

# GENERAL SAFETY RULES

---



## **WARNING!**

### **READ AND UNDERSTAND ALL INSTRUCTIONS.**

Failure to follow all instructions listed below may result in serious personal injury.







---

## **SAVE THESE INSTRUCTIONS**

- **Supervision of athletes while using the equipment is recommended.** Horse play such as climbing on the machine or using the machine for unintended purpose can result in injuries.
- **Athletes should be oriented in the proper use of the equipment.**
- **Athletes should be properly fit to engage in a workout regimen.** Obtaining a medical exam prior to beginning any exercise program is recommended. If an Athlete feels faint, dizzy, or experiences pain at any time while exercising; stop exercising and consult a physician.
- **Athletes should wear close fitting clothing to keep the clothing free from and clear of all moving parts.**
- **Inspect equipment prior to use.** DO NOT use if it appears damaged or inoperable.
- **This Product Information Packet is an integral part of this machine.** Save these instructions. If they are lost or damaged or if you would like another copy, a copy can be downloaded from [www.RogersAthletic.com](http://www.RogersAthletic.com).
- **Reading the Product Information Packet is recommended.** Failure to read this Packet is considered a misuse of this equipment.
- **Warning labels are an integral part of this machine.** Become familiar with all caution/warning labels and never cover or deface caution/warning labels.
- **Install the equipment allowing sufficient room for safe access to the machine, adequate room for the spotters to stand and to ensure that the machine does not collide with a wall or another machine through the entire range of motion.**
- **Use of a spotter is recommended.** Spotters should stand behind the athlete using the machine or to either side of the athlete.
- **Stay clear of all pinch points.** Instruct all athletes to keep fingers away from the weight arm and away from moving parts that may present danger of pinching.
- **Unit is designed for performing the traditional Lat Pull exercises using only authorized Rogers Athletic handles.** Do not use weight equipment for anything other than its approved purpose or with other handles or pulling devices.
- **Equipment is designed for use by one person at a time.** Keeping other athletes and spectators away from the machines during use is recommended.
- **Anchoring the machine in place is recommended.** The Pendulum Lat Combo Pull by Rogers Athletic has built-in anchor points allowing it to be bolted down. Rogers Athletic is not responsible for the installation of the anchors. Use a Professional contractor to anchor the machine(s). Use 3/8" grade 5 or better fasteners.

# SYMBOLS

---

	<p><b>Safety Alert:</b> Precautions that involve your safety.</p>				
<table border="1"><tr><td colspan="2" data-bbox="224 625 656 674"><b>⚠ WARNING</b></td></tr><tr><td data-bbox="233 688 412 877"></td><td data-bbox="412 688 656 877">To avoid personal injury, do not use this equipment until properly trained.</td></tr></table>	<b>⚠ WARNING</b>			To avoid personal injury, do not use this equipment until properly trained.	<p><b>Athletes must be properly trained before using equipment.</b> Failure to train athletes may result in personal injury.</p>
<b>⚠ WARNING</b>					
	To avoid personal injury, do not use this equipment until properly trained.				
<table border="1"><tr><td colspan="2" data-bbox="224 919 656 968"><b>⚠ CAUTION</b></td></tr><tr><td data-bbox="233 982 412 1171"></td><td data-bbox="412 982 656 1171">Pinch Point. Keep hands and fingers clear.</td></tr></table>	<b>⚠ CAUTION</b>			Pinch Point. Keep hands and fingers clear.	<p><b>Pinch Point Symbol:</b> Failure to keep hands away from pinch points may result in personal injury.</p>
<b>⚠ CAUTION</b>					
	Pinch Point. Keep hands and fingers clear.				

# ROGERS ATHLETIC WEIGHT EQUIPMENT SPECIFICATIONS

## PENDULUM LAT COMBO PULL MACHINE

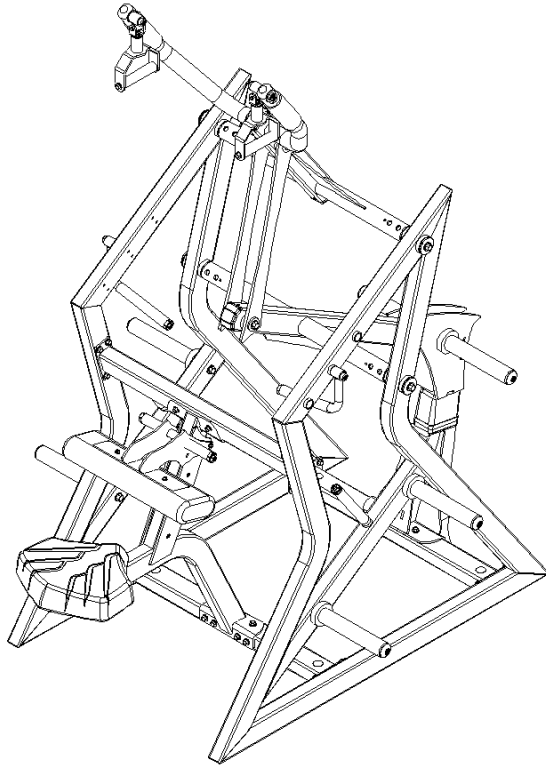

Weight:	500 lbs
Height:	89 3/16"
Length:	73 3/16"
Width:	59"

- Four replaceable weight horns for plate storage.
- Weight horns constructed of steel insert with HDPE plastic sleeve for long life and ease of weight placement.
- Multiple Comfortable articulated handles allow for varying grip styles to optimize training specific muscle groups.
- Equipped for floor anchorage.
- Diamond Rubber grips for greater grasp and comfort.
- Seat and thigh cushions made of self skinning urethane foam
- Thigh restraint enables a safe and comfortable routine, while minimizing movement.

### Lat Machine Construction, Finish, and Hardware

- Constructed of ASTM specified steel.
- Weight Horn Construction: Steel insert.
- Baked-on Powder coat finish.
- Zinc plated hardware Grade 5 or equivalent.
- Grips covered with Diamond Rubber material or equivalent.

# USER INSTRUCTIONS

1

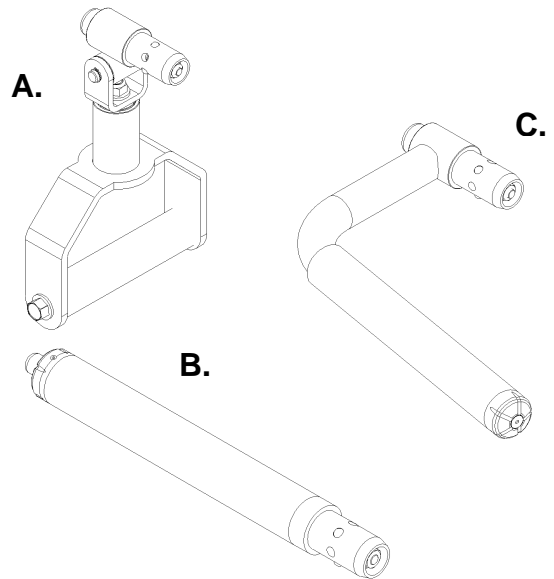
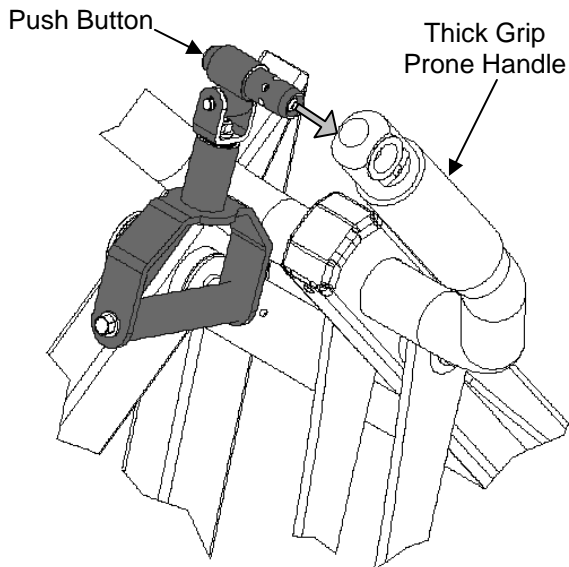

All three handles: A.) Swivel Handle B.) Straight Bar Outside Grip Handle C.) Ergo Bent Inside Grip Handle attach to the weight arms by way of push button ball bearing connection. When you attach a handle to the weight arm, push the button to release locking for inserting and simply force the ball bearing connection end into the receiver till it clicks fastened. To remove a handle, press the push button and pull the handle out of the connection.

2

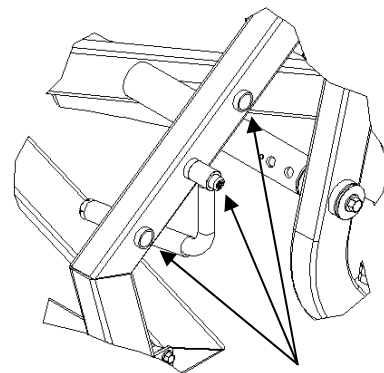
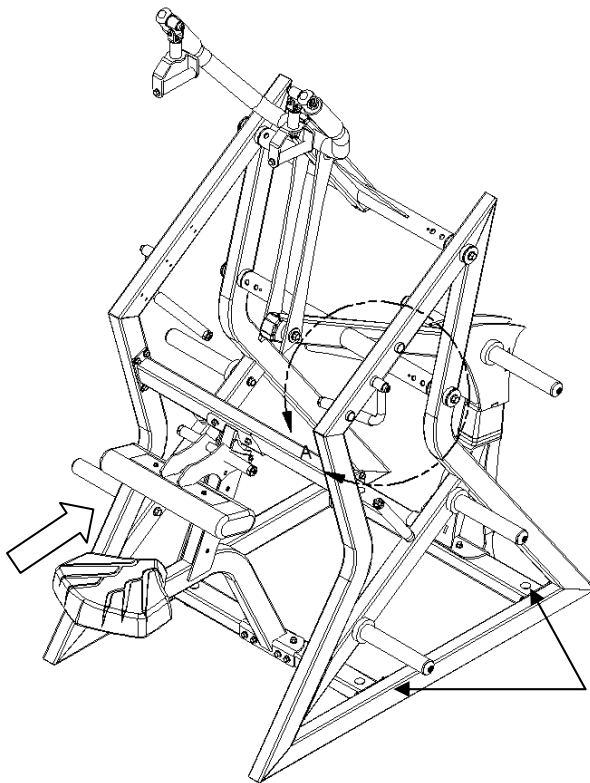

Dock Handles in the Storage Tubes on Both Sides

Level the machine, then remove plugs and anchor the machine to the floor with bolts

Stand facing the machine and grab the handles. Then sit down on the seat. Bump the thigh pad to let it fall to restrain leg movement and secure lower body.

## Disassembly to Move Unit

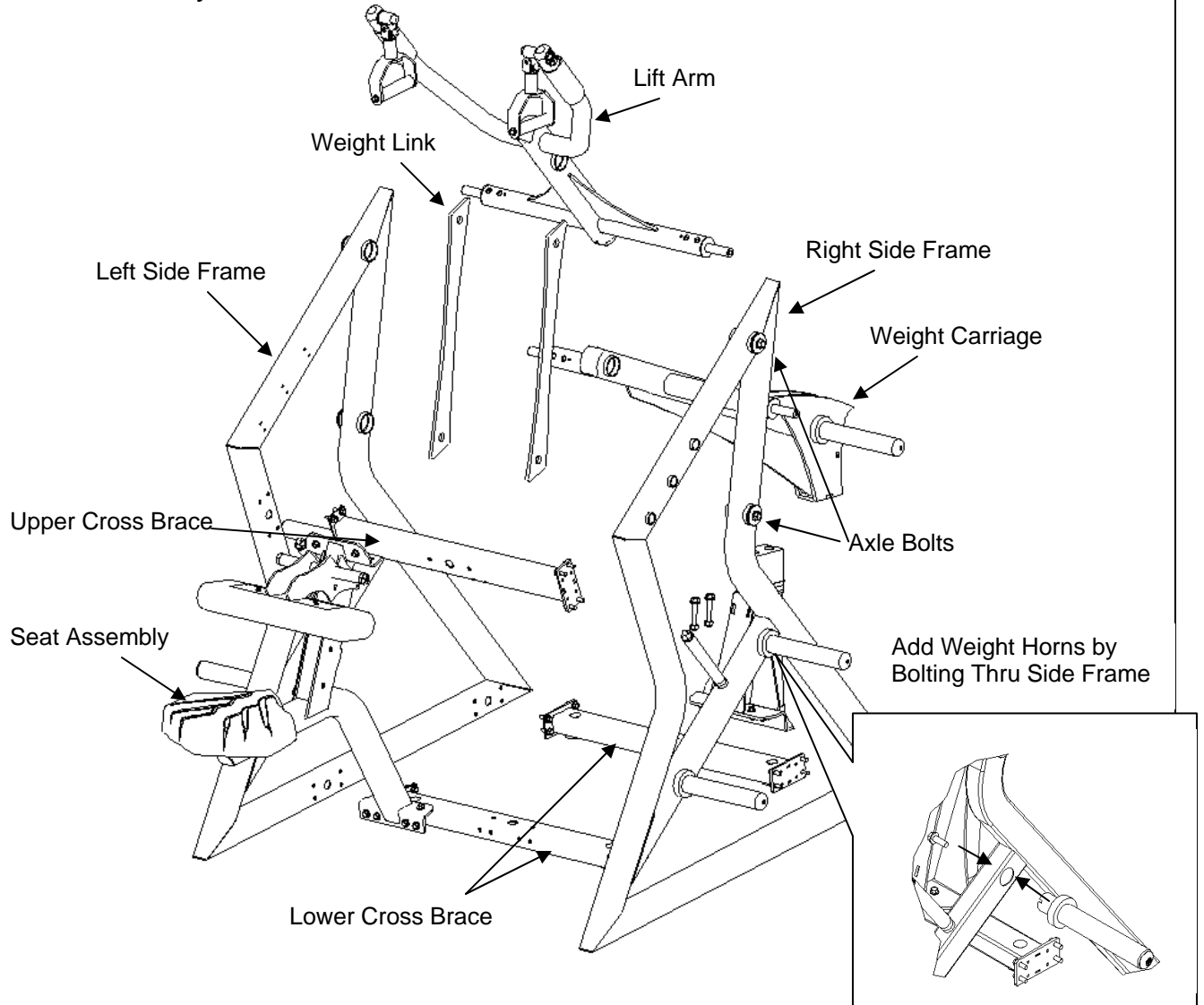

**CAUTION: AVOID INJURY BY TYING DOWN WEIGHT ARMS AND ASSEMBLIES SO THEY DON'T FLAIL LOOSELY IN TRANSPORT. ALWAYS DISSEMBLE WITH PARTNER.**

1. Remove all weight plates from storage Horns and weight arms.
2. With a partner, disassemble the weight links from the weight carriage and lift arm and carefully hold and swing each assembly to a resting point.
3. Remove the seat assembly by removing the bolts and set aside.
4. Disassemble axle bolts.
5. Remove one side frame at a time by removing the 4 bolts on Upper and Lower Cross Braces. Have a helper hold the side frame while removing the bolts.
6. Carefully, take down the lift arm and weight carriage with a helper while removing the side frames. Each assembly can now be moved through any side door or hallway.
7. To reassemble, reverse process but do not tighten bolts until all assemblies are reassembled. Tighten bolts, remove straps, replace Seat Assembly, Links, Carriage, and Arm. Unit is ready to operate.

# MAINTENANCE

---



## **WARNING!**

### **READ AND UNDERSTAND ALL MAINTENANCE PROCEDURES.**

Failure to follow all procedures listed below may cause serious injury and/or decrease equipment functionality.

---

- **Frequently check to see that all bolts are securely fastened.**
- **Frequently check to see that weight equipment is functioning properly.**
- **Touch up paint may be used to cover scratches or blemishes sustained through use.**
- **A silicone based lubricant may be used on moving parts to maintain proper function.**
- **Mild detergent or disinfectant may be used to clean weight equipment.**
- **Replace any damaged equipment with genuine Rogers Athletic parts.** Failure to do so may result in unsafe equipment and/or personal injury.

# CUSTOMER SERVICE

---

For parts or service contact Rogers Athletic Company. When ordering parts be sure to provide all relevant information available including the name and part number of the equipment purchased. This information is located on the cover of this product information package. Customer service hours are Monday through Friday from 8:00 a.m. to 5:00 p.m. Eastern Standard Time. Customers can phone (989) 386-2950 or toll free at (800) 457-5337. Fax toll free at (888) 549-9659 or mail to:

Rogers Athletic Company  
3760 W. Ludington Drive  
Farwell, MI 48622

Rogers Athletic Company  
3760 N. Ludington Drive  
Farwell, MI 48622  
[www.rogersathletic.com](http://www.rogersathletic.com)  
(989) 386-2950  
(800) 457-5337  
Fax toll free (888) 549-9659