



ROGGEERS

For the Perfection of Football Fundamentals™

PRODUCT INFORMATION PACKET

PRODUCT NAME: RUNNING ROPES

PRODUCT PART NUMBER: 410450

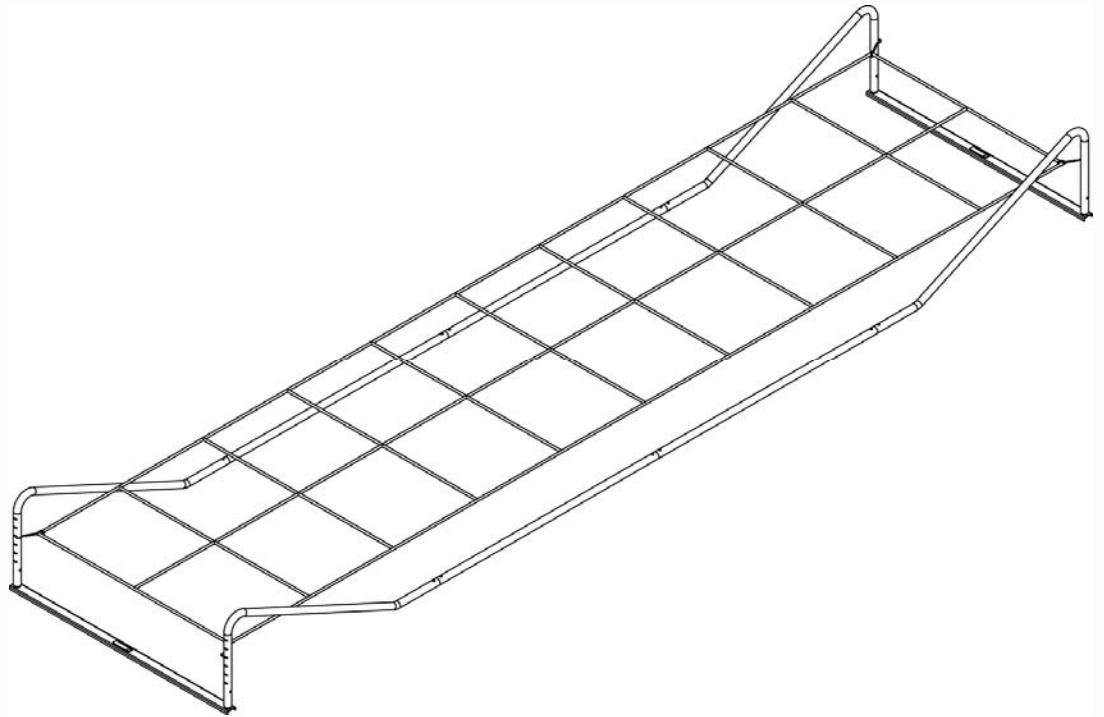

KEEP INFORMATION PACKET FOR FUTURE REFERENCE

TABLE OF CONTENTS

- Introduction.....1
- General Safety Rules.....2
- Symbols.....3
- Technical Specifications.....4
- Assembly Instructions.....5
- Maintenance.....7
- Customer Service Information.....7

INTRODUCTION

The Rogers Athletic Running Ropes have been designed and manufactured with safety, performance and dependability as top priorities, making it easy to operate and maintain.

The care you give your Running Rope will greatly determine your satisfaction with its performance and service life. Careful study of this manual is encouraged to obtain a thorough understanding of your new Running Rope and its functions and maintenance.

If your manual becomes lost or destroyed, Rogers Athletic will gladly provide you with a new copy. Should you require additional information or assistance, please feel free to contact us at 1-800-457-5337.

BECAUSE ROGERS ATHLETIC MAINTAINS AN ONGOING PROGRAM OF
PRODUCT DEVELOPMENT AND IMPROVEMENT, WE RESERVE THE RIGHT
TO MAKE IMPROVEMENTS IN DESIGN OR CHANGES IN SPECIFICATIONS
WITHOUT INCURRING ANY OBLIGATIONS TO INSTALL THEM ON UNITS
PREVIOUSLY SOLD.

GENERAL SAFETY RULES



WARNING!





READ AND UNDERSTAND ALL INSTRUCTIONS.

Failure to follow all instructions listed below may result in serious personal injury.

SAVE THESE INSTRUCTIONS

- **Supervision of athletes while using the equipment is recommended.** Horse play such as climbing on the machine or using the machine for unintended purpose can result in injuries.
- **Athletes should be oriented in the proper use of the equipment.**
- **Athletes should be properly fit to engage in a workout regimen.** Obtaining a medical exam prior to beginning any training program is recommended. If an athlete feels faint, dizzy, or experiences pain at any time while exercising, they should stop exercising and consult a physician.
- **Inspect equipment prior to use.** DO NOT use if it appears damaged or inoperable.
- **This Product Information Packet is an integral part of this machine.** Save these instructions. If they are lost or damaged or if you would like another copy, a copy can be downloaded from www.RogersAthletic.com
- **Reading the Product Information Packet is recommended.** Failure to read this Packet is considered a misuse of this equipment.
- **Warning labels are an integral part of this equipment.** Become familiar with all caution/warning labels and never cover or deface caution/warning labels.
- **Deploy the equipment allowing sufficient room for safe access to the machine, adequate room for the coaches to stand and to ensure that the machine or players do not collide with a wall, another machine, or other players through the entire training exercise.**
- **Unit is designed for training running form with proper technique.** Do not use running ropes for anything other than its approved purpose.
- **Equipment is designed for use by one person per unit at a time.** Keeping other athletes and spectators away from the machines during use is recommended.
- **Design and execute training drills to avoid players from attempting to run through the same ropes simultaneously.** Colliding players could come in contact with the unit and/or connecting links resulting in an injury.
- **When not in use, store this equipment in a secure controlled area.** Unsupervised and/or inappropriate use of this equipment could result in serious injury.

SYMBOLS

	<p>Safety Alert: Precautions that involve your safety.</p>
 <div data-bbox="391 495 612 688" style="border: 1px solid black; padding: 5px;"> <p>⚠ WARNING</p> <p>Pinch Point. Keep hands and fingers clear.</p> </div>	<p>Pinch Point Symbol: Failure to keep hands away from pinch points may result in personal injury.</p>
<div data-bbox="198 743 607 989" style="border: 1px solid black; padding: 5px;"> <p>⚠ WARNING</p>  <p>Store in secure area. Inappropriate use of this equipment could result in serious injury.</p> </div>	<p>Store this equipment in a secure, controlled area: Unsupervised and/or inappropriate use of this equipment could result in serious injury.</p>
 <div data-bbox="391 1020 612 1213" style="border: 1px solid black; padding: 5px;"> <p>⚠ WARNING</p> <p>Avoid Injury. Do not climb.</p> </div>	<p>Do Not Climb Warning Label: To reduce risk of injury, do not climb on field equipment.</p>

ROGERS ATHLETIC RUNNING ROPES SPECIFICATIONS

RUNNING ROPES (PART# 410450)

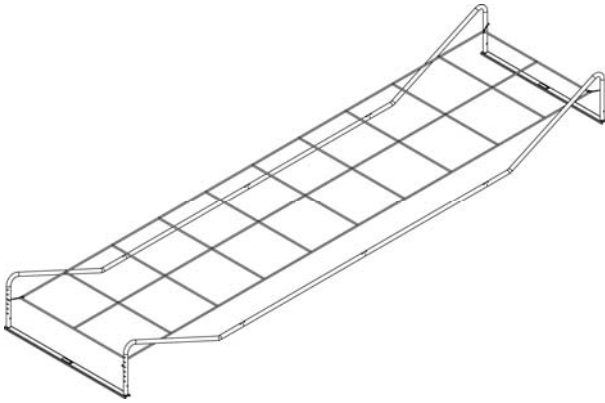

Weight:	69 lbs (31 kg)
Height:	24" (61cm)
Length:	234" (594cm)
Width:	59" (150cm)

- Webbing adjusts in height from 7"-17".
- Curved corner uprights reduce risk of injury.
- No tools necessary for assembly.
- Flat channel end braces and lack of cross braces in running area reduce trip hazards.

Running Ropes Construction, Finish, and Hardware

- Constructed of ASTM specified steel.
- Baked-on powder coat finish.
- Zinc-plated hardware.

1

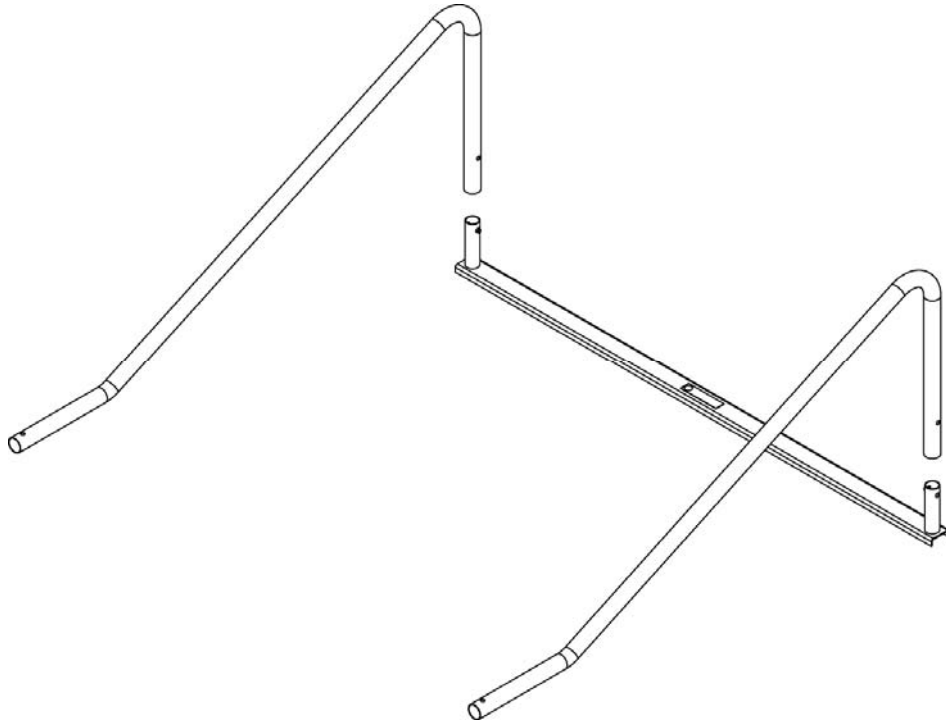

Attach two Running Rope leg tubes to one of the End Frame Sub-Assemblies. An audible click should be heard when the tubes engage.

2

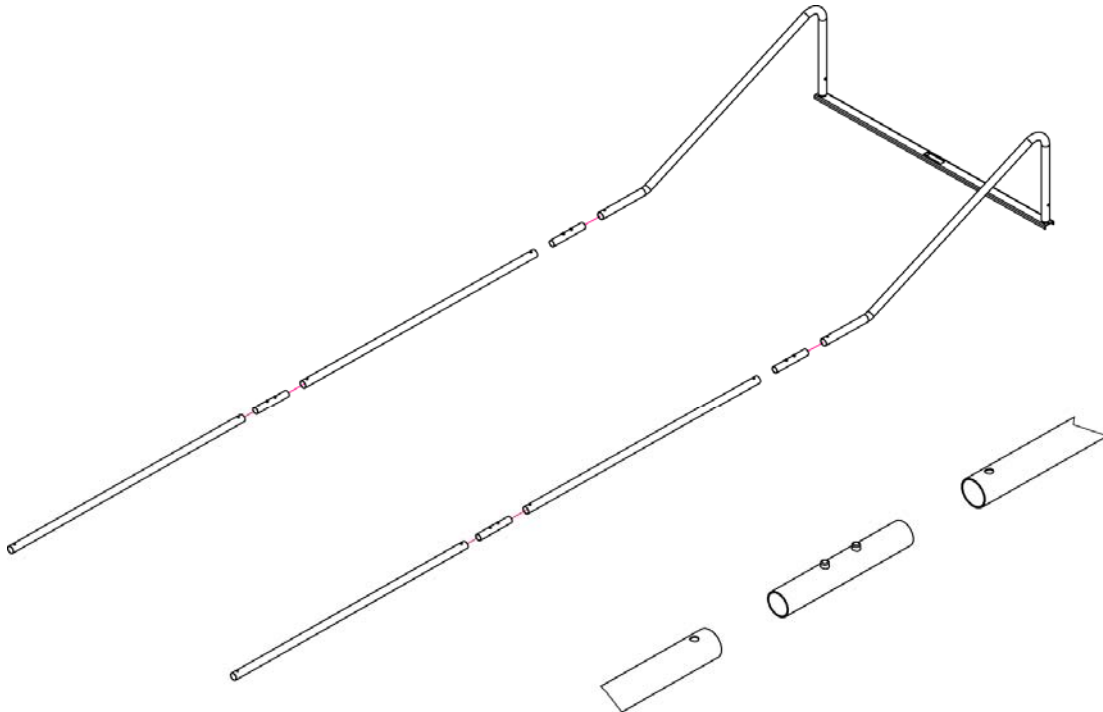

Use (4) Insert Tubes to connect Center Tubes to leg tubes as shown. Again you should hear an audible click when tube inserted to correct position.

3

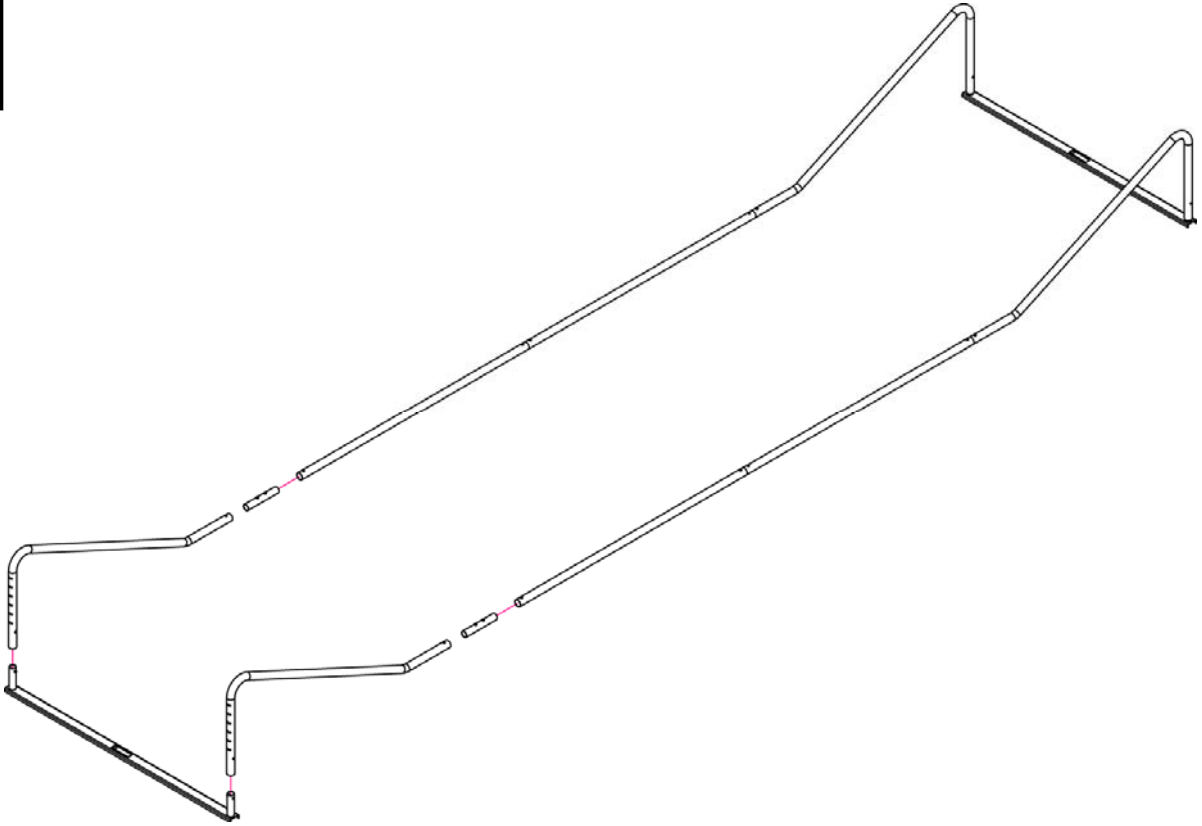

Attach the remaining leg tubes and end frame sub-assembly using the same methods as in steps 1 & 2.

4

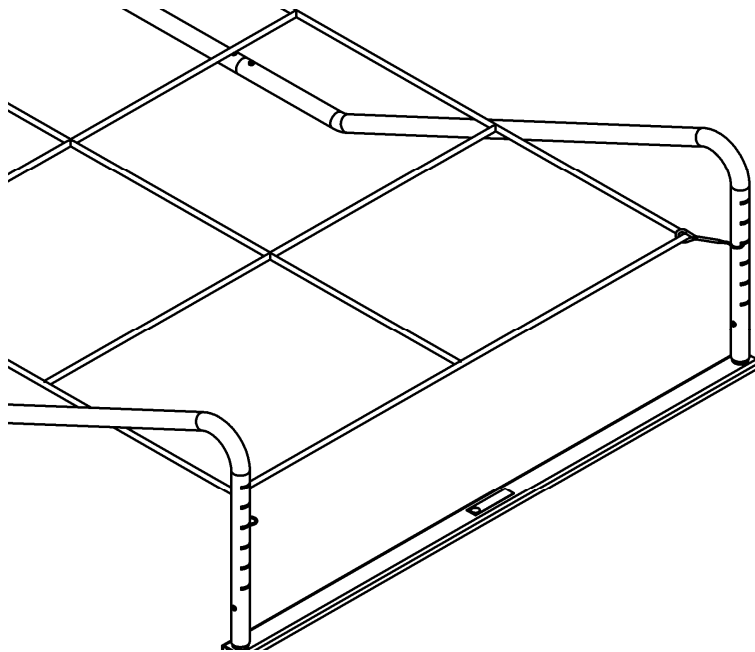

Attach the ropes with the hook on the bungee cord by inserting the hook into the slot on the uprights that is the desired height. Attach one corner at a time. Attaching the corners in different slot heights will increase difficulty.

MAINTENANCE



WARNING!

READ AND UNDERSTAND ALL MAINTENANCE PROCEDURES.

Failure to follow all procedures listed below may cause serious injury and/or a decrease in equipment functionality.

- **Frequently check to see that all connections are securely fastened.**
- **Touch up paint may be used to cover scratches or blemishes sustained through use.**
- **Field equipment should be washed periodically with soapy water to maintain original surface finish.**
- **Replace any damaged equipment with genuine Rogers Athletic parts.** Failure to do so may result in unsafe equipment and/or personal injury.

CUSTOMER SERVICE

For parts or service contact Rogers Athletic Company. When ordering parts be sure to provide all relevant information available including the name and part number of the equipment purchased. This information is located on the cover of this product information package. Customer service hours are Monday through Friday from 8:00 a.m. to 5:00 p.m. Eastern Standard Time. Customers can phone (989) 386-2950 or toll free at 1-800-457-5337. Fax toll free at (888) 549-9659 or mail to:

Rogers Athletic Company
3760 W. Ludington Drive
Farwell, MI 48622

Rogers Athletic Company
3760 N. Ludington Drive
Farwell, MI 48622
www.rogersathletic.com
(989) 386-2950
(800) 457-5337
Fax toll free (888) 549-9659