



# ROGGEERS

*For the Perfection of Football Fundamentals™*

## PRODUCT INFORMATION PACKET

PRODUCT NAME: **SHIVER SLED**

PRODUCT PART NUMBER: 410377

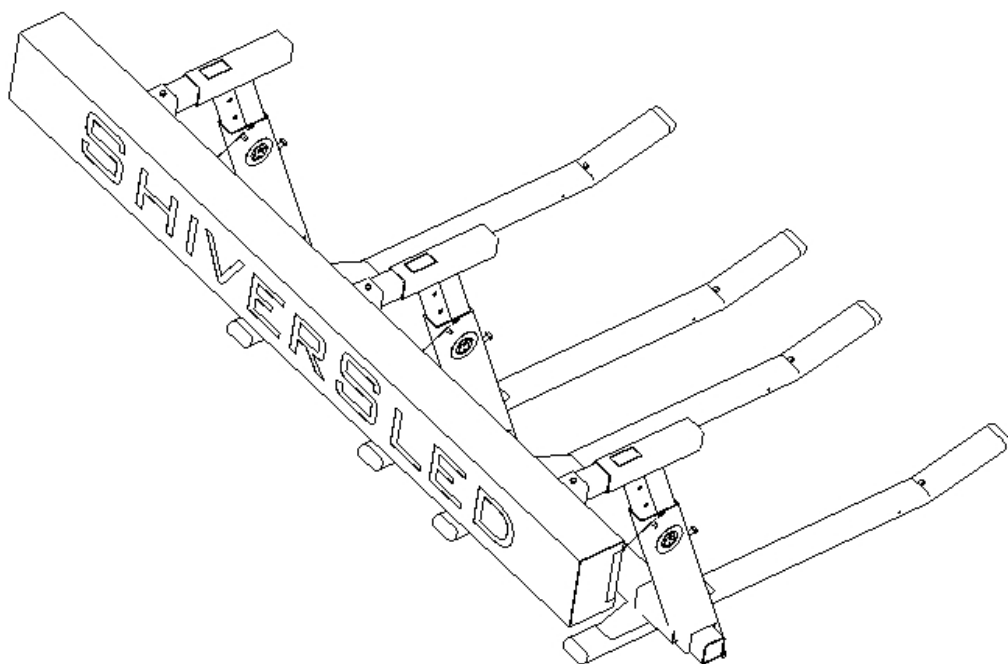

**KEEP INFORMATION PACKET FOR FUTURE REFERENCE**

# TABLE OF CONTENTS

---

- Introduction.....1
- General Safety Rules.....2
- Symbols.....3
- Technical Specifications.....4
- Assembly Instructions.....5
- Maintenance.....7
- Customer Service Information.....7

## INTRODUCTION

---

The Rogers Athletic Shiver Sled has been designed and manufactured with safety, performance and dependability as top priorities, making it easy to operate and maintain.

The care you give your Shiver Sled will greatly determine your satisfaction with its performance and service life. Careful study of this manual is encouraged to obtain a thorough understanding of your new Shiver Sled and its functions and maintenance.

If your manual becomes lost or destroyed, Rogers Athletic will gladly provide you with a new copy. Should you require additional information or assistance, please feel free to contact us at 1-800-457-5337.

BECAUSE ROGERS ATHLETIC MAINTAINS AN ONGOING PROGRAM OF  
PRODUCT DEVELOPMENT AND IMPROVEMENT, WE RESERVE THE RIGHT  
TO MAKE IMPROVEMENTS IN DESIGN OR CHANGES IN SPECIFICATIONS  
WITHOUT INCURRING ANY OBLIGATIONS TO INSTALL THEM ON UNITS  
PREVIOUSLY SOLD.

# GENERAL SAFETY RULES

---



## **WARNING!**

### **READ AND UNDERSTAND ALL INSTRUCTIONS.**

Failure to follow all instructions listed below may result in serious personal injury.



---

## **SAVE THESE INSTRUCTIONS**

- **Supervision of athletes while using the equipment is recommended.** Horse play such as climbing on the machine or using the machine for unintended purpose can result in injuries.
- **Athletes should be oriented in the proper use of the equipment.**
- **Athletes should be properly fit to engage in a workout regimen.** Obtaining a medical exam prior to beginning any training program is recommended. If an athlete feels faint, dizzy, or experiences pain at any time while exercising, they should stop exercising and consult a physician.
- **Inspect equipment prior to use.** DO NOT use if it appears damaged or inoperable.
- **This Product Information Packet is an integral part of this machine.** Save these instructions. If they are lost or damaged or if you would like another copy, a copy can be downloaded from [www.RogersAthletic.com](http://www.RogersAthletic.com)
- **Reading the Product Information Packet is recommended.** Failure to read this Packet is considered a misuse of this equipment.
- **Warning labels are an integral part of this equipment.** Become familiar with all caution/warning labels and never cover or deface caution/warning labels.
- **Deploy the equipment allowing sufficient room for safe access to the machine, adequate room for the coaches to stand and to ensure that the machine or players do not collide with a wall, another machine, or other players through the entire training exercise.**
- **Unit is designed for training multiple offensive and defensive drills with proper technique.** Do not use Shiver Sled for anything other than its approved purpose.
- **Always wear a helmet when using the Shiver Sled.**
- **Equipment is designed for use by one person per pad at a time.** Keeping other athletes and spectators away from the machines during use is recommended.
- **Design and execute training drills to avoid players from attempting to run through the same gap between the sled units simultaneously.** Colliding players could come in contact with the sled unit and/or connecting link resulting in an injury.
- **When not in use, store this equipment in a secure controlled area.** Unsupervised and/or inappropriate use of this equipment could result in serious injury.

# SYMBOLS

---

	<p><b>Safety Alert:</b> Precautions that involve your safety.</p>
	<p><b>Store this equipment in a secure, controlled area:</b> Unsupervised and/or inappropriate use of this equipment could result in serious injury.</p>
	<p><b>Pinch Point Symbol:</b> Failure to keep hands away from pinch points may result in personal injury.</p>

# ROGERS ATHLETIC SHIVER SLED SPECIFICATIONS

## SHIVER SLED (PART # 410377)

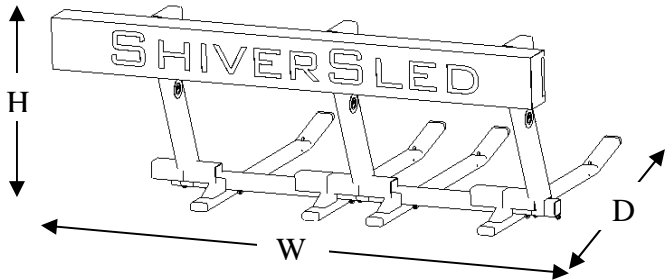

Weight:	695 lbs (315 kg)
Height:	42" to 54" (107 to 137cm)
Depth:	99" (251cm)
Width:	120" (305 cm)

- Spring-loaded setup provides resistance to players' punches.
- 10 foot long pad allows multiple players to run drills at the same time.
- Pad height adjusts to best suit your players.
- Pad is 12" high x 10' Long

## Shiver Sled Construction, Finish, and Hardware

- Construction: made of ASTM specified steel
- Baked-on powder coat finish
- Zinc-plated hardware
- Durable 18oz vinyl

# ASSEMBLY INSTRUCTIONS

1

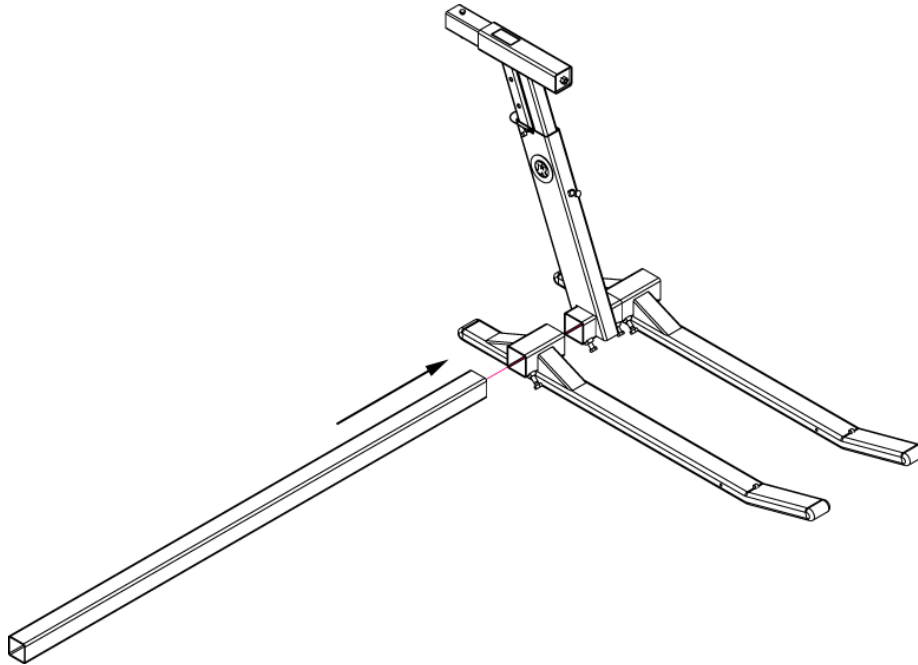

**Assembly requires at least two people.**

First, layout two Shiver Sled runners with a ram sub-assembly between them, as shown then thread the 8' base tube through the sled runner and tubes as shown. **Tip:** Do not tighten any bolts until everything has been put together. This will make it easier to line it all up with the pad and ensure a proper functioning sled.

2

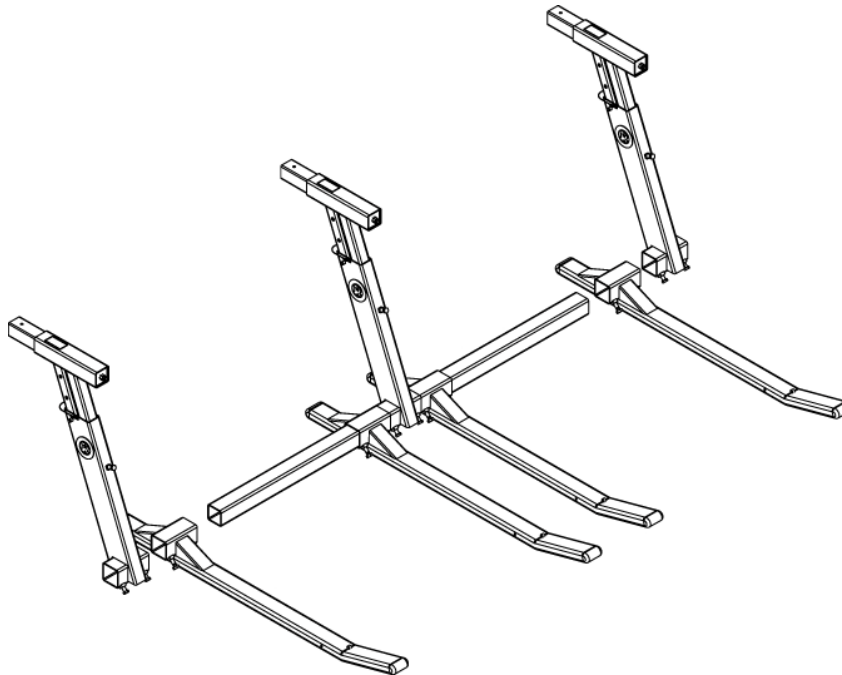

Next, fit another Shiver Sled runner and ram sub-assembly on each end of the base tube, as shown. The runners should be on the inside of each ram sub-assembly. Before fitting the pad, check that the two end ram sub-assemblies are flush with the ends of the base tube. Check that the middle ram assembly is 44" from the outside to the other ram assemblies.

3

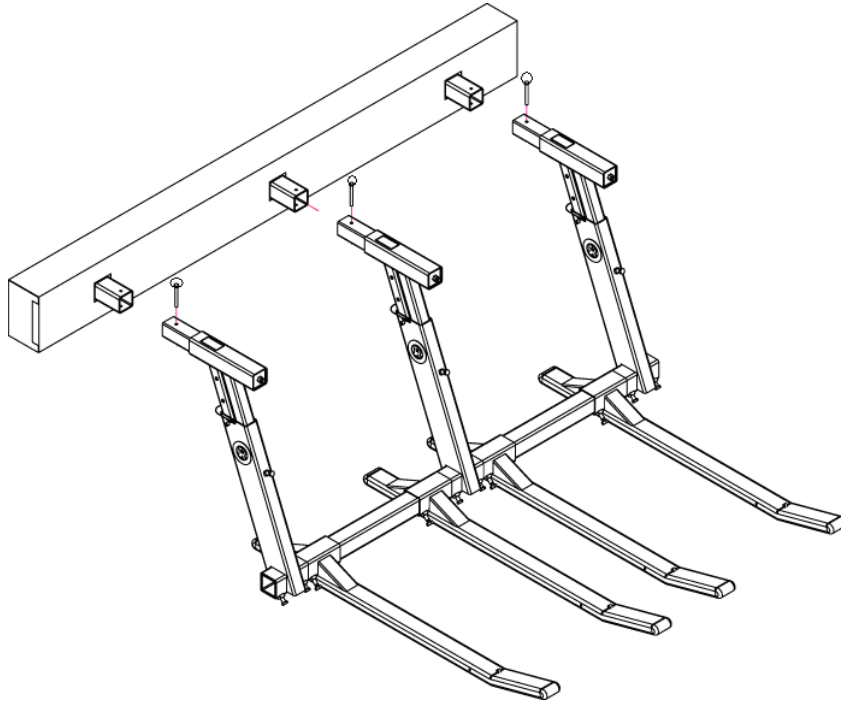

Be sure the bolts are loose throughout the sled and fit the tubes of the pad over the ram tubes of the ram sub-assemblies. Use (3) fas-pins to fasten the pad to the sled assembly. With the pad bolted in place, push the pad several times at each ram location to settle the alignment, and then tighten all bolts.

## MAINTENANCE

---



### **WARNING!**

### **READ AND UNDERSTAND ALL MAINTENANCE PROCEDURES.**

Failure to follow all procedures listed below may cause serious injury and/or a decrease in equipment functionality.

---

- **Frequently check to see that all bolts are securely fastened.**
- **Touch up paint may be used to cover scratches or blemishes sustained through use.**
- **Field equipment should be washed periodically with soapy water to maintain original surface finish.**
- **A silicone based lubricant may be used on moving parts to maintain proper function.**
- **Replace any damaged equipment with genuine Rogers Athletic parts.** Failure to do so may result in unsafe equipment and/or personal injury.

## CUSTOMER SERVICE

---

For parts or service contact Rogers Athletic Company. When ordering parts be sure to provide all relevant information available including the name and part number of the equipment purchased. This information is located on the cover of this product information package. Customer service hours are Monday through Friday from 8:00 a.m. to 5:00 p.m. Eastern Standard Time. Customers can phone (989) 386-2950 or toll free at (800) 457-5337. Fax toll free at (888) 549-9659 or mail to:

Rogers Athletic Company  
3760 W. Ludington Drive  
Farwell, MI 48622

Rogers Athletic Company  
3760 N. Ludington Drive  
Farwell, MI 48622

[www.rogersathletic.com](http://www.rogersathletic.com)

(989) 386-2950

(800) 457-5337

Fax toll free (888) 549-9659