



ROGGIERS
For the Perfection of Football Fundamentals™

PRODUCT INFORMATION PACKET

PRODUCT NAME: SPEED CHUTES

**PRODUCT PART NUMBER: 410149-410153,
410257-410258**

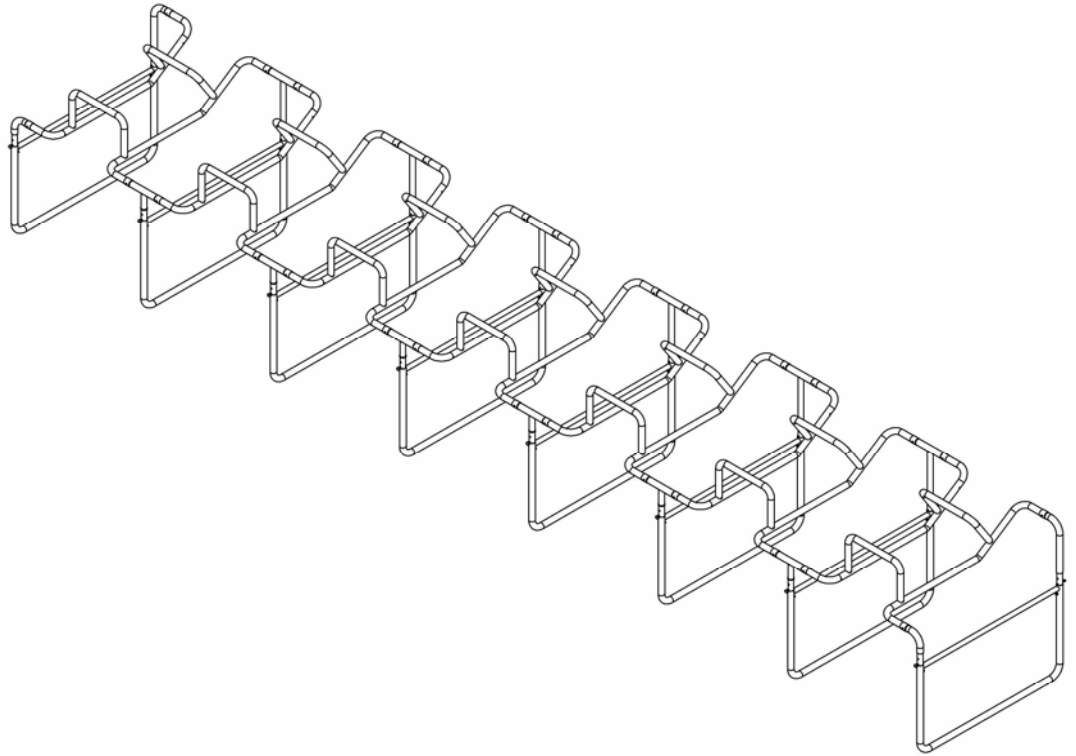

KEEP INFORMATION PACKET FOR FUTURE REFERENCE

TABLE OF CONTENTS

- Introduction.....2
- General Safety Rules.....3
- Symbols.....4
- Technical Specifications.....5
- Assembly Instructions.....6
- Maintenance.....8
- Customer Service Information.....8

INTRODUCTION

The Rogers Athletic Speed Chute has been designed and manufactured with safety, performance and dependability as top priorities, making it easy to operate and maintain.

The care you give your Speed Chute will greatly determine your satisfaction with its performance and service life. Careful study of this manual is encouraged to obtain a thorough understanding of your new Speed Chute and its functions.

If your manual is lost or destroyed, Rogers Athletic will gladly provide you with a new copy. Should you require additional information or assistance, please feel free to contact us at 800-457-5337.

BECAUSE ROGERS ATHLETICS MAINTAINS AN ONGOING PROGRAM OF
PRODUCT DEVELOPMENT AND IMPROVEMENT, WE RESERVE THE RIGHT
TO MAKE IMPROVEMENTS IN DESIGN OR CHANGES IN SPECIFICATIONS
WITHOUT INCURRING ANY OBLIGATIONS TO INSTALL THEM ON UNITS
PREVIOUSLY SOLD.

GENERAL SAFETY RULES



WARNING!











READ AND UNDERSTAND ALL INSTRUCTIONS.

Failure to follow all instructions listed below may result in serious personal injury.

SAVE THESE INSTRUCTIONS

- **Supervision of athletes while using the equipment is recommended.** Horse play such as climbing on the machine or using the machine for unintended purpose can result in injuries.
- **Athletes should be oriented in the proper use of the equipment.**
- **Athletes should be properly fit to engage in a workout regimen.** Obtaining a medical exam prior to beginning any training program is recommended. If an athlete feels faint, dizzy, or experiences pain at any time while exercising, they should stop exercising and consult a physician.
- **Inspect equipment prior to use.** DO NOT use if it appears damaged or inoperable.
- **This Product Information Packet is an integral part of this machine.** Save these instructions. If they are lost or damaged or if you would like another copy, a copy can be downloaded from www.RogersAthletic.com
- **Reading the Product Information Packet is recommended.** Failure to read this Packet is considered a misuse of this equipment.
- **Warning labels are an integral part of this equipment.** Become familiar with all caution/warning labels and never cover or deface caution/warning labels.
- **Deploy the equipment allowing sufficient room for safe access to the machine, adequate room for the coaches to stand and to ensure that the machine or players do not collide with a wall, another machine, or other players through the entire training exercise.**
- **Unit is designed for training multiple offensive and defensive drills with proper technique.** Do not use Speed Chute for anything other than its approved purpose.
- **Equipment is designed for use by one person per stall at a time.** Keeping other athletes and spectators away from the machines during use is recommended.
- **Design and execute training drills to avoid players from attempting to run through the same gap in the unit simultaneously.** Colliding players could come in contact with the unit and/or connecting links resulting in an injury.
- **When not in use, store this equipment in a secure controlled area.** Unsupervised and/or inappropriate use of this equipment could result in serious injury.

SYMBOLS

	<p>Safety Alert: Precautions that involve your safety</p>				
<table border="1" style="width: 100%;"> <tr> <td colspan="2" style="background-color: #ff8c00; color: white; text-align: center;">⚠ WARNING</td> </tr> <tr> <td style="width: 30%; text-align: center;">  </td> <td> <p>Store in secure area. Inappropriate use of this equipment could result in serious injury.</p> </td> </tr> </table>	⚠ WARNING			<p>Store in secure area. Inappropriate use of this equipment could result in serious injury.</p>	<p>Store this equipment in a secure, controlled area: Unsupervised and/or inappropriate use of this equipment could result in serious injury.</p>
⚠ WARNING					
	<p>Store in secure area. Inappropriate use of this equipment could result in serious injury.</p>				
<table border="1" style="width: 100%;"> <tr> <td style="width: 30%; text-align: center;">  </td> <td style="background-color: #ffff00; text-align: center;">⚠ CAUTION</td> </tr> <tr> <td colspan="2"> <p>Pinch Point. Keep Hands And Fingers Clear</p> </td> </tr> </table>		⚠ CAUTION	<p>Pinch Point. Keep Hands And Fingers Clear</p>		<p>Pinch Point Symbol: Failure to keep hands away from pinch points will result in personal injury</p>
	⚠ CAUTION				
<p>Pinch Point. Keep Hands And Fingers Clear</p>					
<table border="1" style="width: 100%;"> <tr> <td style="width: 30%; text-align: center;">  </td> <td style="background-color: #ffff00; text-align: center;">⚠ CAUTION</td> </tr> <tr> <td colspan="2"> <p>Avoid Injury. Do not climb.</p> </td> </tr> </table>		⚠ CAUTION	<p>Avoid Injury. Do not climb.</p>		<p>Do Not Climb Warning Label: To reduce risk of injury, do not climb on field equipment</p>
	⚠ CAUTION				
<p>Avoid Injury. Do not climb.</p>					

ROGERS ATHLETIC FIELD EQUIPMENT SPECIFICATIONS

SPEED CHUTES

Description	Part Number	Weight	Dimensions (L x W)	Adjustable Height
1 – Man	410149	105 lb.	56" x 60"	41" – 51"
2 – Man	410150	180 lb.	112" x 60"	41" – 51"
3 – Man	410151	255 lb.	166" x 60"	41" – 51"
4 – Man	410152	330 lb.	221" x 60"	41" – 51"
5 – Man	410153	405 lb.	276" x 60"	41" – 51"
6 – Man	410257	480 lb.	331" x 60"	41" – 51"
7 – Man	410258	555 lb.	385" x 60"	41" – 51"

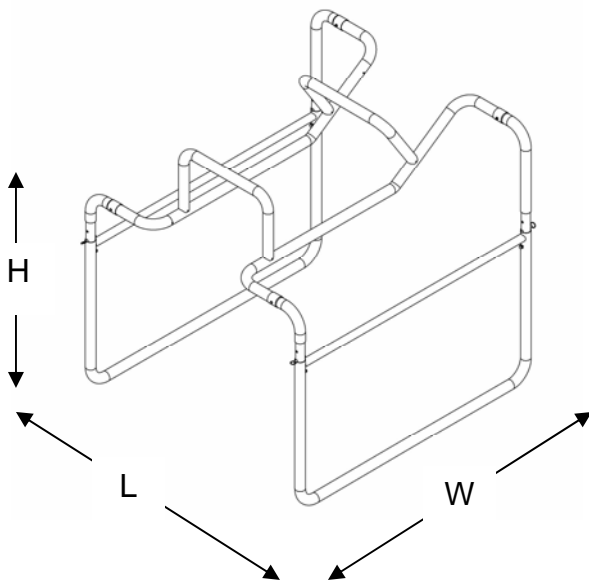

- Design allows the athletes to keep their shoulders low while at the same time keeping their heads up
- Adjust shoulder height from 41" to 51"
- Design allows for one to seven man chute configurations.

Field Equipment Construction, Finish, and Hardware

- Constructed of ASTM specified steel.
- Hardware Zinc plated to resist corrosion
- Durable Powdercoat finish for years of performance

1

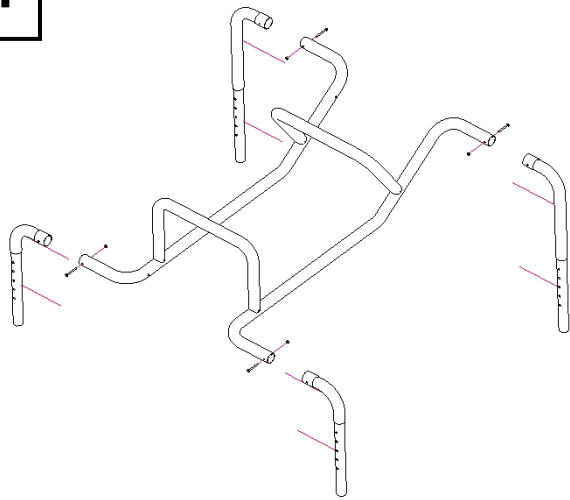

Note: Only for Single Man Chutes, 2-7 Man Chutes, skip to Step 3

Insert (4) Chute Elbows into Chute Top, Place (4) 1/4" bolts and (4) 1/4" nuts through Elbow and Top.

2

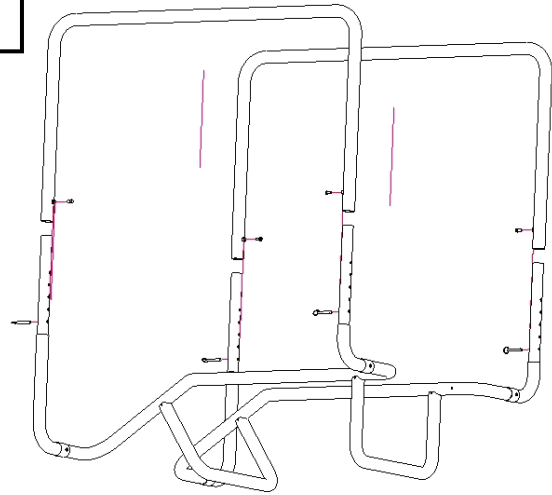

Flip assembly from Step 1 over, insert (4) fas-pins into desired matching heights. Insert runners onto elbows. Place and tighten 3/8" Bolt.

3

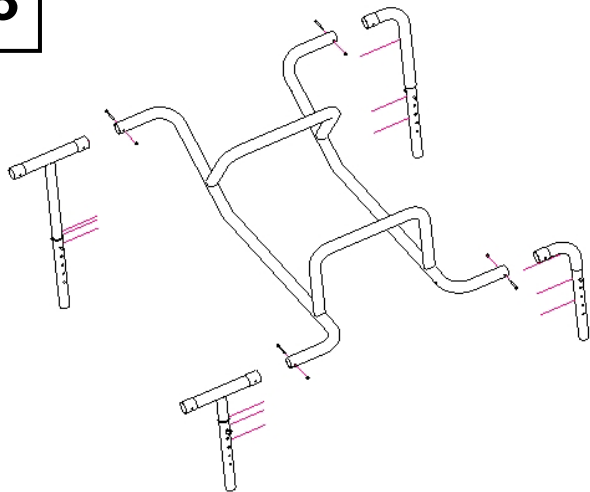

2-7 Man Chute

Insert (2) Chute Elbows into Chute Top. Place (2) 1/4: bolts and (2) 1/4" nuts through Elbow and Top. Insert (2) Chute Tee's into Chute Top. Place (2) 1/4: bolts and (2) 1/4" nuts through Tee and Top.

4

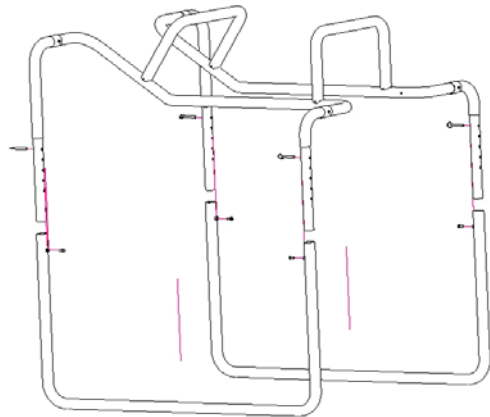

See **Step 2** for adding runners

5

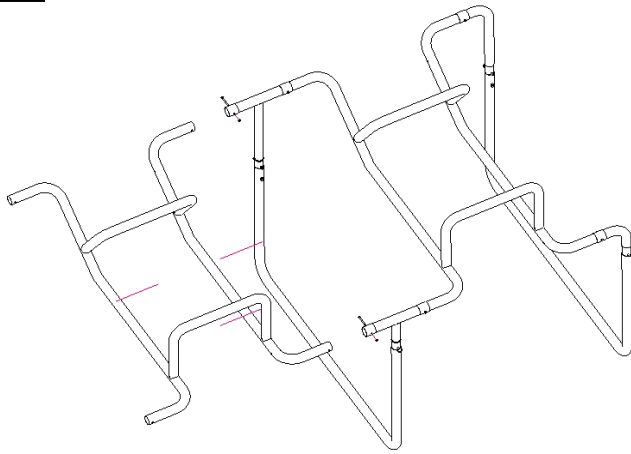

Insert Chute Top into assembly from step 4. Place (2) 1/4" bolts and (2) 1/4" nuts through Top and Tee.

6

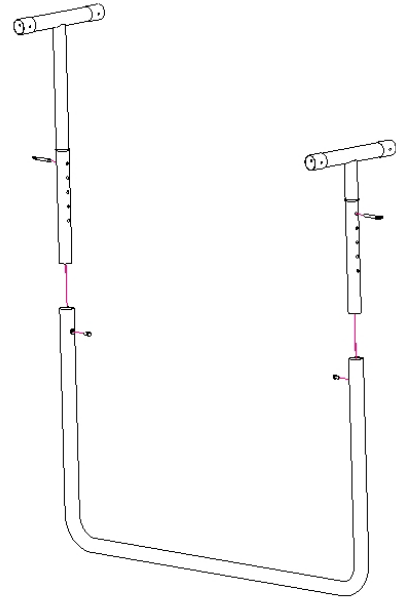

Place fas-pin in each Tee. Insert Tee into runner. Tighten 3/8" Bolts located in runner.

7

Insert Assembly from Step 6 into Step 5. Place (2) 1/4" bolts and (2) 1/4" nuts through Top and Tee. Repeat Steps 5, 6, and 7 until Speed Chute is complete. On the end, elbows will be used instead of Tees.

MAINTENANCE



WARNING!

READ AND UNDERSTAND ALL MAINTENANCE PROCEDURES.

Failure to follow all procedures listed below may cause serious injury and a decrease in the equipments functional existence.

- **Frequently check to see that all bolts are securely fastened.**
- **Field equipment should be washed periodically with soapy water to maintain original surface finish.**
- **Touch up paint can be used to cover any scratches or blemishes sustained through use.**
- **A silicone based lubricant may be used on moving parts to maintain proper function.**
- **Replace any damaged equipment with genuine Rogers Athletic parts.** Failure to do so may result in unsafe equipment and/or personal injury.

CUSTOMER SERVICE

For parts or service contact Rogers Athletic Company. When ordering parts be sure to provide all relevant information available including the name and part number of the equipment purchased. This information is located on the cover of this product information package. Customer service hours are Monday through Friday from 8:00 a.m. to 5:00 p.m. Eastern Standard Time. Customers can phone (989) 386-2950 or toll free at 1-800-457-5337. Fax toll free at (888) 549-9659 or mail:

Rogers Athletic Company
3760 W. Ludington Drive
Farwell, Michigan 48622

Rogers Athletic Company
3760 N. Ludington Drive
Farwell, MI 48622
www.rogersathletic.com
(989) 386-2950
(800) 457-5337
Fax toll free (888) 549-9659

PIPSPEEDCHUTE