

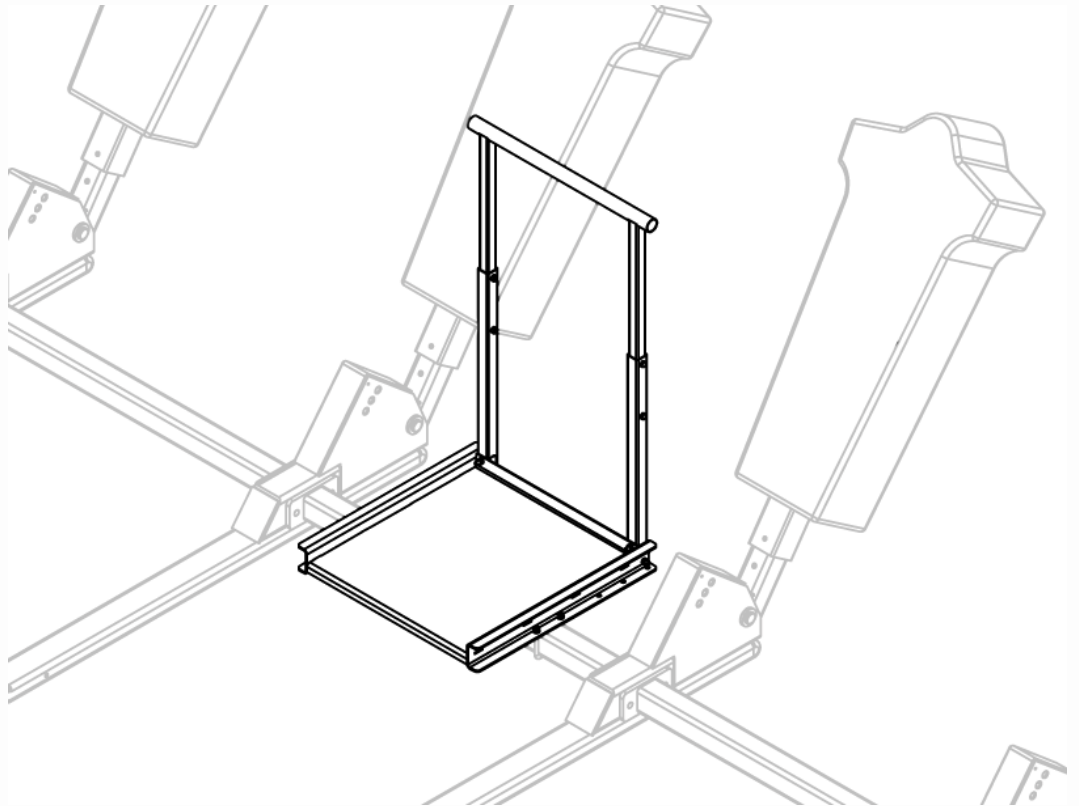

ROGGEERS

For the Perfection of Football Fundamentals™

PRODUCT INFORMATION PACKET
PRODUCT NAME: COACH'S PLATFORM
PRODUCT PART NUMBER: 411309



KEEP INFORMATION PACKET FOR FUTURE REFERENCE

TABLE OF CONTENTS

- Introduction.....1
- General Safety Rules.....2
- Symbols.....3
- Technical Specifications.....4
- User Instructions.....5
- Maintenance.....6
- Customer Service Information.....6

INTRODUCTION

The Rogers Athletic Coach's Platform has been designed and manufactured with safety, performance and dependability as top priorities, making it easy to operate and maintain.

The care you give your Coach's Platform will greatly determine your satisfaction with its performance and service life. Careful study of this manual is encouraged to obtain a thorough understanding of your new Coach's Platform and its functions.

If your manual is lost or destroyed, Rogers Athletic will gladly provide you with a new copy. Should you require additional information or assistance, please feel free to contact us at 800-457-5337.

BECAUSE ROGERS ATHLETIC MAINTAINS AN ONGOING PROGRAM OF
PRODUCT DEVELOPMENT AND IMPROVEMENT, WE RESERVE THE RIGHT
TO MAKE IMPROVEMENTS IN DESIGN OR CHANGES IN SPECIFICATIONS
WITHOUT INCURRING ANY OBLIGATIONS TO INSTALL THEM ON UNITS
PREVIOUSLY SOLD.

GENERAL SAFETY RULES



WARNING!







READ AND UNDERSTAND ALL INSTRUCTIONS.

Failure to follow all instructions listed below may result in serious personal injury.

SAVE THESE INSTRUCTIONS

- **Obtain a medical exam prior to beginning any exercise program.** Use equipment only if properly fit to engage in physical activity.
- **Stop exercising if you feel faint, dizzy, or experience pain at any time while exercising and consult your physician.**
- **Use field equipment in a supervised environment with proper gear.**
- **Keep body and clothing free from and clear of all moving parts**
- **Inspect equipment prior to use. DO NOT use if it appears damaged or inoperable.**
- **Save these instructions.** Refer to them frequently and use them to instruct others who may use the Coach's Platform. If you loan someone your Coach's Platform, loan them these instructions also.
- **Read the Product Information Packet.** Failure to read the information packet is considered a misuse of this equipment.
- **Become familiar with all caution and warning decals affixed to the field equipment before use.**
- **Never cover or deface caution/warning labels.**

SYMBOLS

	<p>Safety Alert: Precautions that involve your safety.</p>		
<table border="1"><tr><td data-bbox="198 632 423 858"></td><td data-bbox="423 632 683 858"><p>⚠ WARNING</p><p>Avoid Injury. Do not climb.</p></td></tr></table>		<p>⚠ WARNING</p> <p>Avoid Injury. Do not climb.</p>	<p>Do Not Climb Symbol: Climbing on or playing around equipment may result in personal injury.</p>
	<p>⚠ WARNING</p> <p>Avoid Injury. Do not climb.</p>		
<table border="1"><tr><td data-bbox="198 926 423 1152"></td><td data-bbox="423 926 683 1152"><p>⚠ WARNING</p><p>Read and understand operator's manual and all other safety instructions before using this equipment.</p></td></tr></table>		<p>⚠ WARNING</p> <p>Read and understand operator's manual and all other safety instructions before using this equipment.</p>	<p>Read the Operator's Manual: To reduce risk of injury, user must read and understand operator's manual before using this product.</p>
	<p>⚠ WARNING</p> <p>Read and understand operator's manual and all other safety instructions before using this equipment.</p>		

ROGERS ATHLETIC FIELD EQUIPMENT SPECIFICATIONS

DRIVE SLED (PART# 410588)

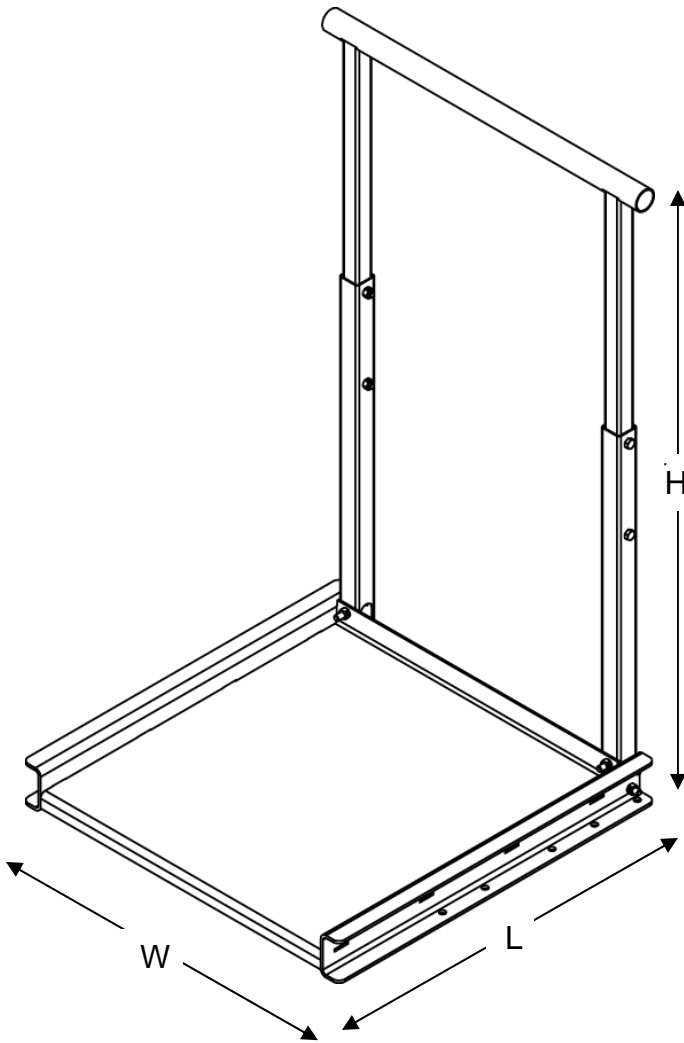

Weight:	54 lbs (25 kg)
Height:	44" (112cm)
Length:	26" (66cm)
Width:	26" (66cm)

- Allows Coach to watch the force and technique of each player as he drills.
- Fits Lev, Mod, and Powerline Sleds.

Drive Sled Construction, Finish, and Hardware

- Constructed of ASTM specified steel.
- Baked-on powder coat finish.
- Zinc-plated hardware.

ASSEMBLY INSTRUCTIONS

1

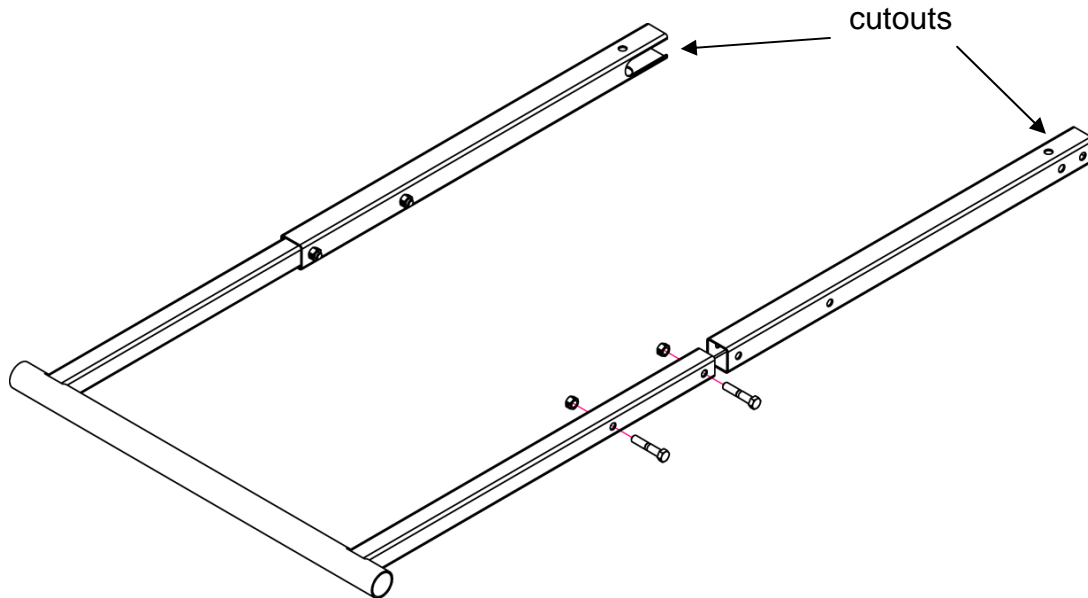

Lay out the handle parts aligning the lower tubes so that the cutouts are facing in. Attach lower handle tubes to upper handle with (4) 3/8-16 x 2" bolts and nuts.

2

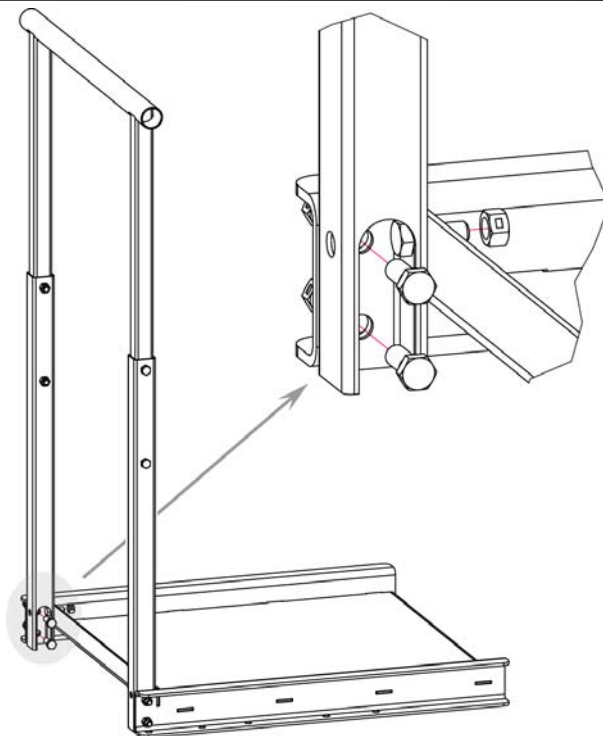

Place handle in the corner formed by the side channel and the base plate. Attach with (6) 3/8-16 x 1" bolts and nuts.

3

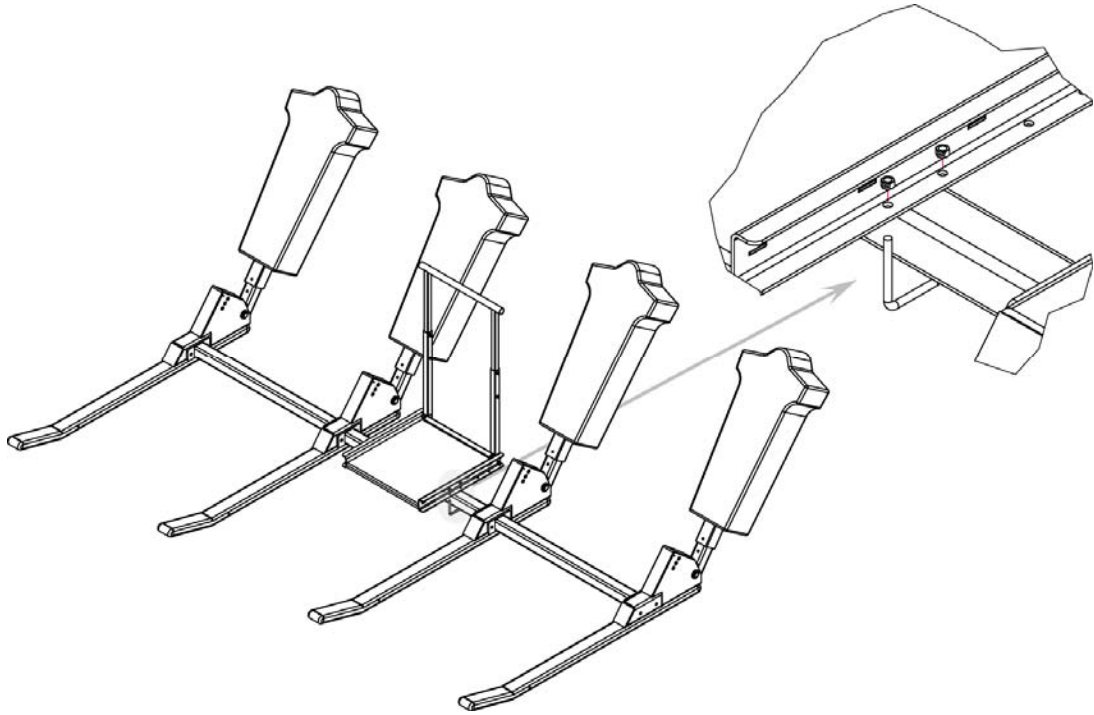

Attach Coach's Platform to sled using the supplied U bolts, washers and nuts.

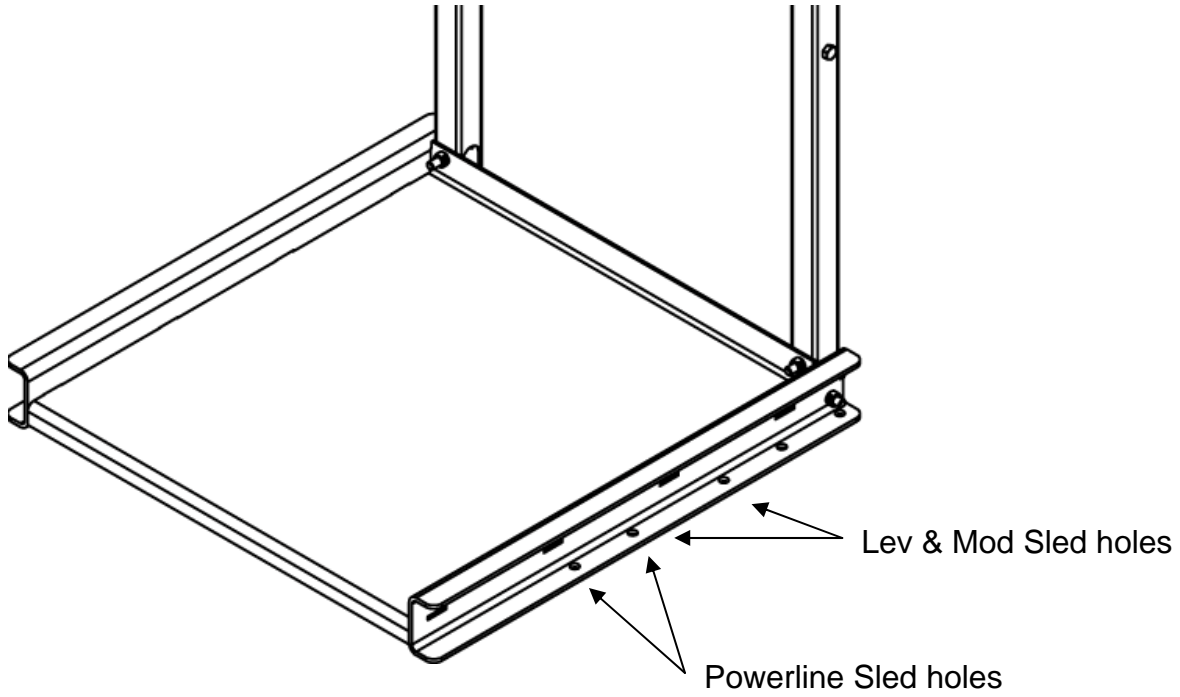

MAINTENANCE



WARNING!

READ AND UNDERSTAND ALL MAINTENANCE PROCEDURES.

Failure to follow all procedures listed below may cause serious injury and/or decrease equipment functionality.

- **Frequently check to see that all bolts are securely fastened.**
- **Touch up paint may be used to cover scratches or blemishes sustained through use.**
- **Scratches and rust will occur on the pan from normal use.**
- **Field equipment should be washed periodically with soapy water to maintain original surface finish.**
- **Replace any damaged equipment with genuine Rogers Athletic parts.** Failure to do so may result in unsafe equipment and/or personal injury.

CUSTOMER SERVICE

For parts or service contact Rogers Athletic Company. When ordering parts be sure to provide all relevant information available including the name and part number of the equipment purchased. This information is located on the cover of this product information package. Customer service hours are Monday through Friday from 8:00 a.m. to 5:00 p.m. Eastern Standard Time. Customers can phone (989) 386-2950 or toll free at (800) 457-5337. Fax toll free at (888) 549-9659 or mail to:

Rogers Athletic Company
3760 W. Ludington Drive
Farwell, MI 48622

Rogers Athletic Company
3760 N. Ludington Drive
Farwell, MI 48622
www.rogersathletic.com
(989) 386-2950
(800) 487-5337
Fax toll free (888) 549-9659