



ROGERS

PRODUCT INFORMATION PACKET

PENDULUM FULL RACK

PRODUCT PART NUMBER: 410706

PATENTS: #D562670, PATENT PENDING

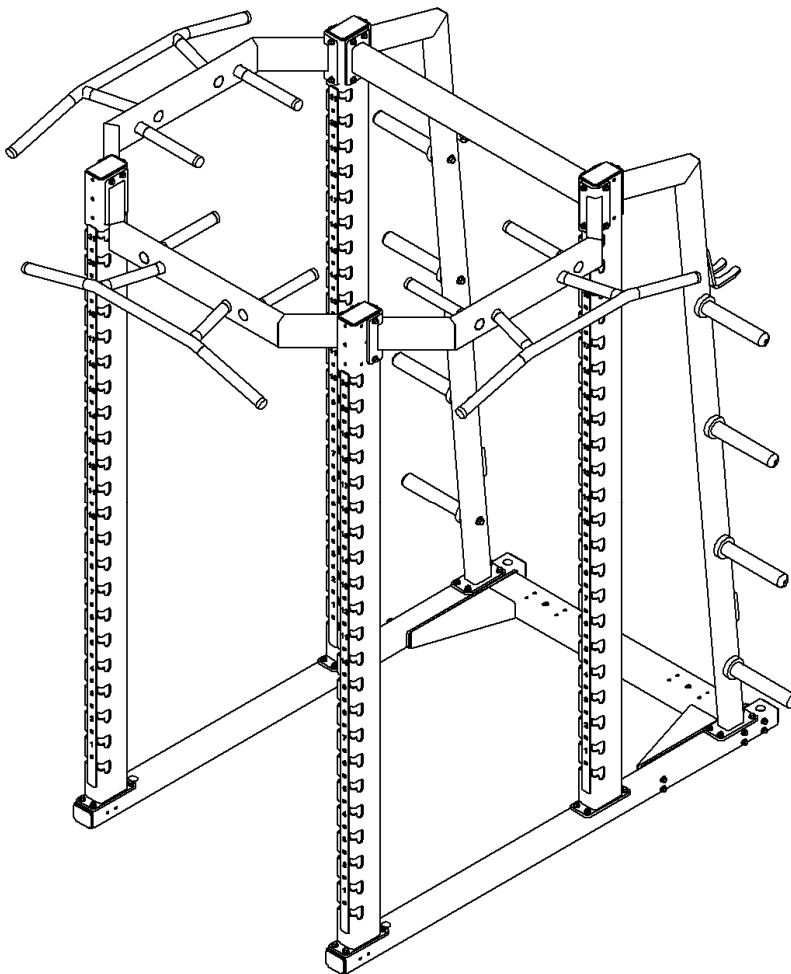

Pendulum Full Rack shown with optional pull-up arches.

KEEP INFORMATION PACKET FOR FUTURE REFERENCE

TABLE OF CONTENTS

- Introduction.....1
- General Safety Rules.....2
- Symbols.....4
- **Pendulum Full Rack**
- Technical Specifications.....5
- Assembly Instructions.....6
- **Mid Section Bar**
- Technical Specifications.....8
- Assembly Instructions.....9
- **Pendulum Lock-N-Load Hook**
- Technical Specifications.....10
- Assembly Instructions.....11
- Maintenance.....
- Customer Service Information.....12

INTRODUCTION

The Rogers Athletic Pendulum Rack System™ has been designed and manufactured with safety, performance and dependability as top priorities, making it easy to operate and maintain.

The care you give your Pendulum Rack System™ will greatly determine your satisfaction with its performance and service life. Careful study of this manual is encouraged to obtain a thorough understanding of your new Pendulum Rack System™ and its functions.

If your manual is lost or destroyed, Rogers Athletic will gladly provide you with a new copy. Should you require additional information or assistance, please feel free to contact us at 800-457-5337.

BECAUSE ROGERS ATHLETIC MAINTAINS AN ONGOING PROGRAM OF
PRODUCT DEVELOPMENT AND IMPROVEMENT, WE RESERVE THE RIGHT
TO MAKE IMPROVEMENTS IN DESIGN OR CHANGES IN SPECIFICATIONS
WITHOUT INCURRING ANY OBLIGATIONS TO INSTALL THEM ON UNITS
PREVIOUSLY SOLD.

GENERAL SAFETY RULES



WARNING!

READ AND UNDERSTAND ALL INSTRUCTIONS.

Failure to follow all instructions listed below may result in serious personal injury.

SAVE THESE INSTRUCTIONS

- **Supervision of athletes while using the equipment is recommended.** Horse play such as climbing on the machine or using the machine for unintended purpose can result in injuries.
- **Athletes should be oriented in the proper use of the equipment.**
- **Athletes should be properly fit to engage in a workout regimen.** Obtaining a medical exam prior to beginning any exercise program is recommended. If an athlete feels faint, dizzy, or experiences pain at any time while exercising, they should stop exercising and consult a physician.
- **Athletes should wear close fitting clothing to keep the clothing free from and clear of all moving parts.**
- **Inspect equipment prior to use.** DO NOT use if it appears damaged or inoperable.
- **This Product Information Packet is an integral part of this machine.** Save these instructions. If they are lost or damaged or if you would like another copy, a copy can be downloaded from www.RogersAthletic.com
- **Reading the Product Information Packet is recommended.** Failure to read this Packet is considered a misuse of this equipment.
- **Warning labels are an integral part of this machine.** Become familiar with all caution/warning labels and never cover or deface caution/warning labels.
- **Install the equipment allowing sufficient room for safe access to the machine, adequate room for the spotters to stand and to ensure that the machine does not collide with a wall or another machine through the entire range of motion.**
- **Set up Pendulum Full Rack™ on level surface.** Accessories such as Monster Arms™, Lock-N-Load Hook™, Technique Trays, Safety Bars and Spotter Platforms may not work properly if Pendulum Full Rack™ is assembled on uneven ground.
- **Use of a spotter is recommended.** Spotters should stand behind the athlete using the machine or to either side of the athlete.
- **Stay clear of all pinch points.** Instruct all athletes to keep fingers away from the weight arm and away from moving parts that may present danger of pinching.
- **Unit is designed for performing a squat with proper technique using only authorized Rogers Athletic components.** Do not use weight equipment for anything other than its approved purpose.



- **Equipment is designed for use by one person at a time.** Keeping other athletes and spectators away from the machines during use is recommended.

- **Anchor all Pendulum Racks to the floor.** All racks have built-in anchor points to allow them to be bolted down. A non-anchored rack may be unstable, unsafe, and compromise performance. Rogers Athletic is not responsible to install the anchors. A Professional Contractor should be contacted to anchor the rack(s). 3/8" grade 5 or better fasteners must be used.

- **A clean workout environment is recommended to avoid trip hazards.**

- **Questions or comments?** Please contact Rogers Athletic by phone (1-800-457-5337), or visit our website at www.RogersAthletic.com

SYMBOLS

	<p>Safety Alert: Precautions that involve your safety.</p>
	<p>Athletes must be properly trained before using equipment. Failure to train athletes may result in personal injury.</p>

ROGERS ATHLETIC PENDULUM FULL RACK SPECIFICATIONS

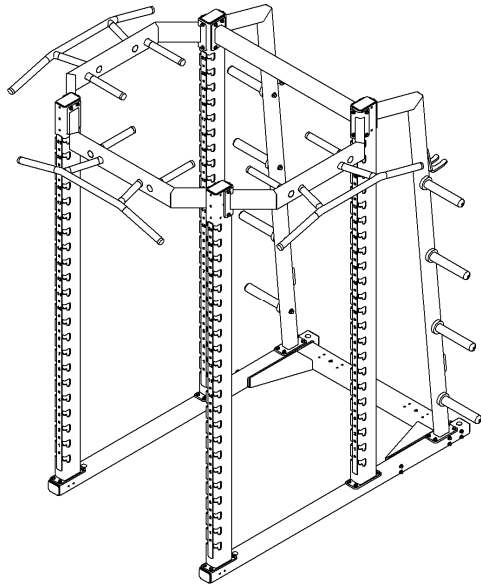

	Pendulum Full Rack (Basic)	(With pull-up bars)
Weight:	630lbs	780lbs
Height:	102"	102"
Length:	80"	93"
Width:	71"	80.5"

- Adjustable settings from 8" to 84" in 4" increments for maximum height versatility.
- Full complements of Pendulum Rack accessories are available.
- Innovative tapered cutouts guide accessories into firm setting.
- Provides locking feature for critical accessories.
- Eight replaceable weight horns for plate storage.
- Weight horns constructed of steel insert with over molded urethane for long life and ease of weight placement.
- Plastic number strip clearly denotes numeric height settings while providing wear protection for the Pendulum Rack System.
- Color choices available.

ASSEMBLY INSTRUCTIONS

1

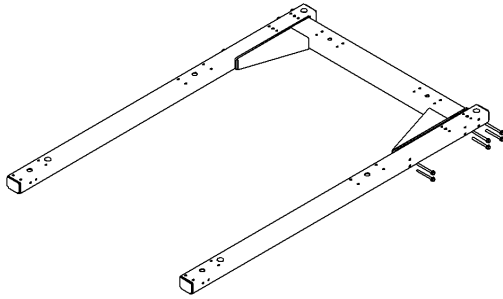

Arrange rack base in desired location ensuring floor is level, then use [12] 3/8" x 4" bolts to fasten the rack legs to the rack base.

2

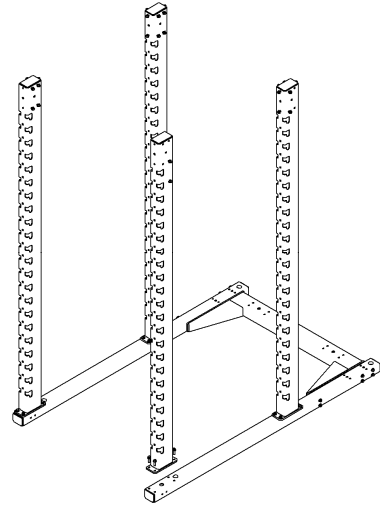

Fasten rack columns using (4) 3/8" X 1 1/4" bolts per column. Do not completely tighten bolts.

3

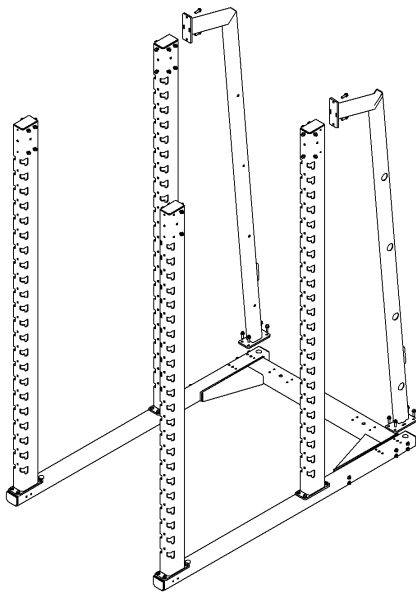

Attach the weight tree using (6) 3/8" X 1 1/4" bolts per side. Make sure to face larger holes outwards. Do not completely tighten bolts.

4

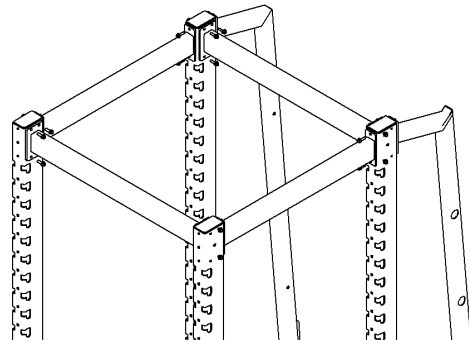

Install the upper braces using 24 3/8" X 1 1/4" bolts (optional chin-up bar may be installed here). **Tighten all bolts on the rack.**

5

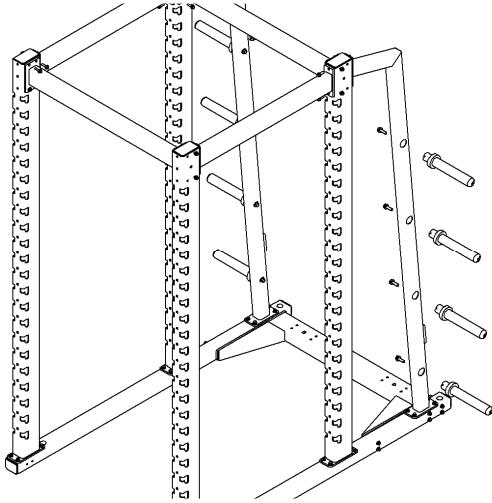

Install (8) weight horns by inserting them into the holes of the weight tree and secure using (8) 1/2" X 1 1/2" bolts. Anchor to floor using 3/8" grade 5 or better fasteners. Insert (4) plugs into holes near end of rack legs.

6

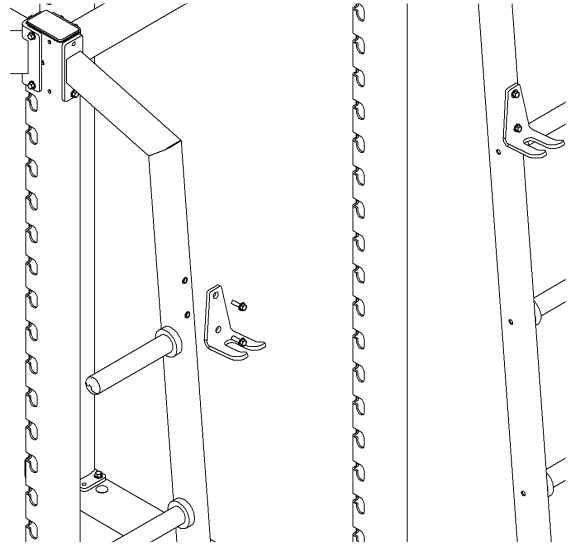

Install bar hangers on back of weight tree using two (2) 3/8" X 1 1/4" bolts per side.

7

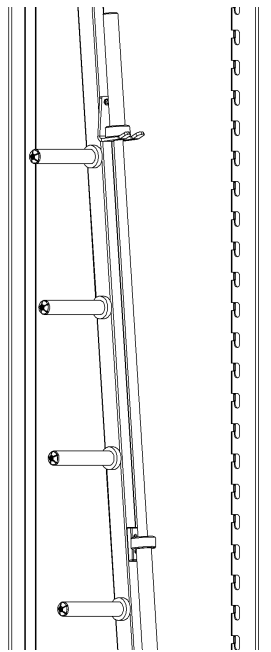

Hang bars on hangers and let rest on rubber bumpers when not using bars

ROGERS ATHLETIC WEIGHT EQUIPMENT SPECIFICATIONS

PENDULUM SAFETY BAR (408388)

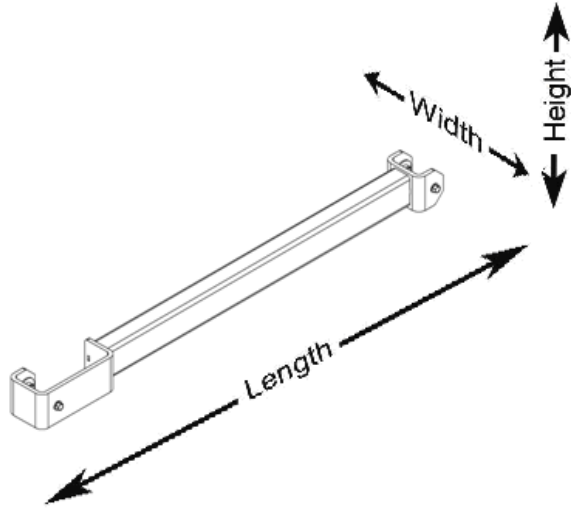

Weight:	28lbs
Height:	3.5"
Length:	46.75"
Width:	4.25"

- Durable urethane coating on wear surfaces provides long finish life.
- Long length to accommodate wide range of exercises.
- Fully welded.

1

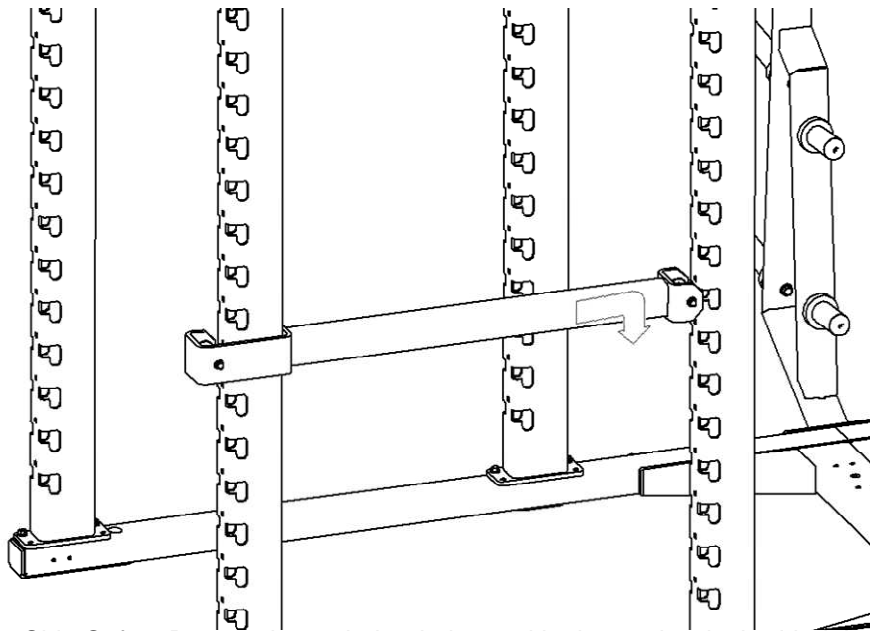

To attach the Side Safety Bars to the rack, begin by positioning at the desired height. Push the bar flat against the rack uprights, then pull down to lock them into place. Position the bars to a functional supporting position corresponding to chosen exercise.

2

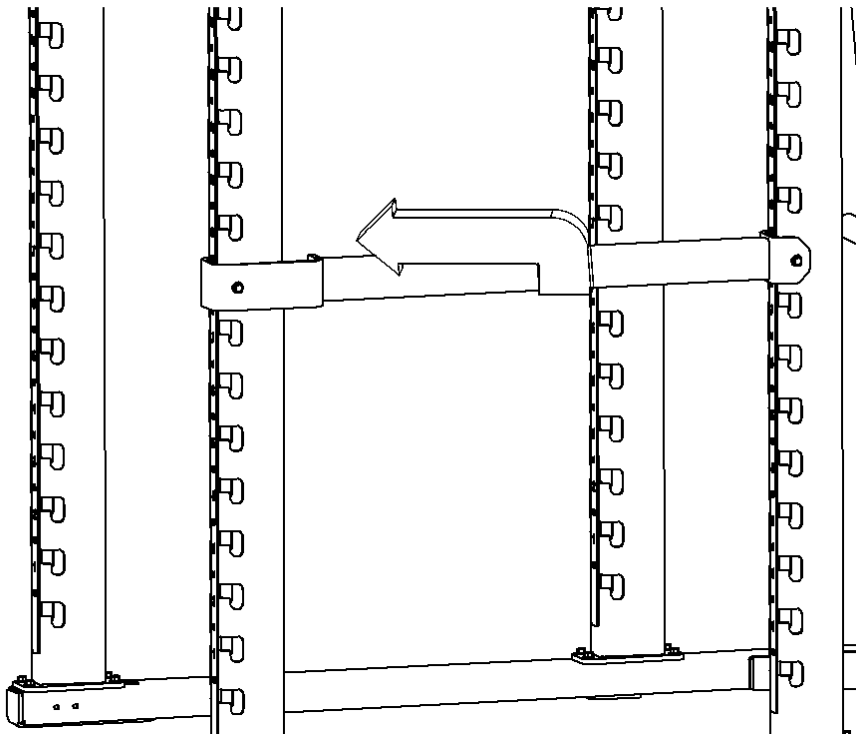

To remove or reposition the bars. lift up and pull them out.

ROGERS ATHLETIC WEIGHT EQUIPMENT SPECIFICATIONS

PENDULUM LOCK - N - LOAD HOOKS (4 1 0 5 1 9)

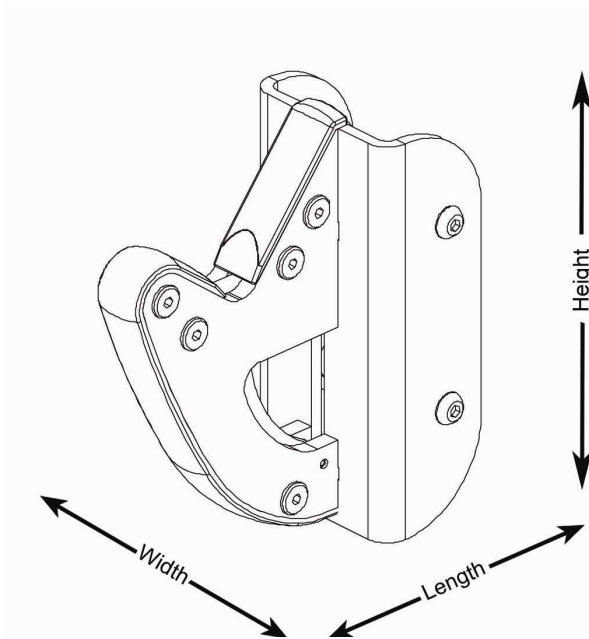

Weight:	22 lbs/set (10 kg)
Height:	9" (23 cm)
Length:	8" (20 cm)
Width:	4.25" (11 cm)

- Automatically locates and locks with trigger release.
- A single hook can be used for both "left/right" and "front/back" rack uprights.
- Durable urethane bumpers.
- Designed to virtually eliminate hook and bar wear, avoiding paint chips and metal shavings which can fall into a lifter's eyes.
- Hardened wear pin allows bar to "slide" side to side eliminating the wear common on other systems

1

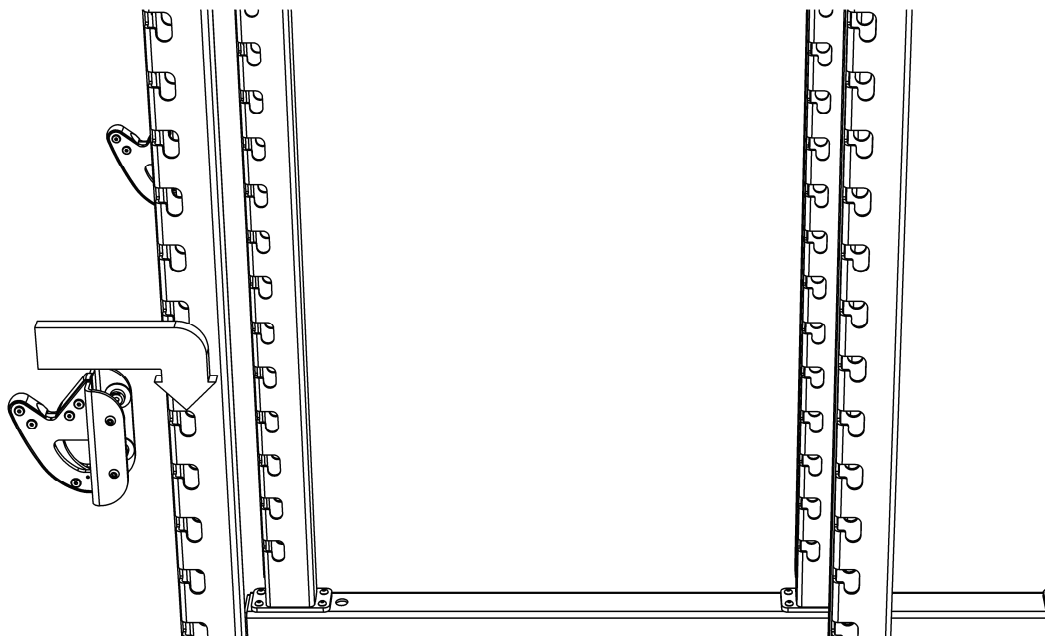

To attach the Lock-N-Load Hooks to the rack, begin by positioning them at the same desired height. Push the hooks flat against the rack uprights, then pull down to lock them into place.

2

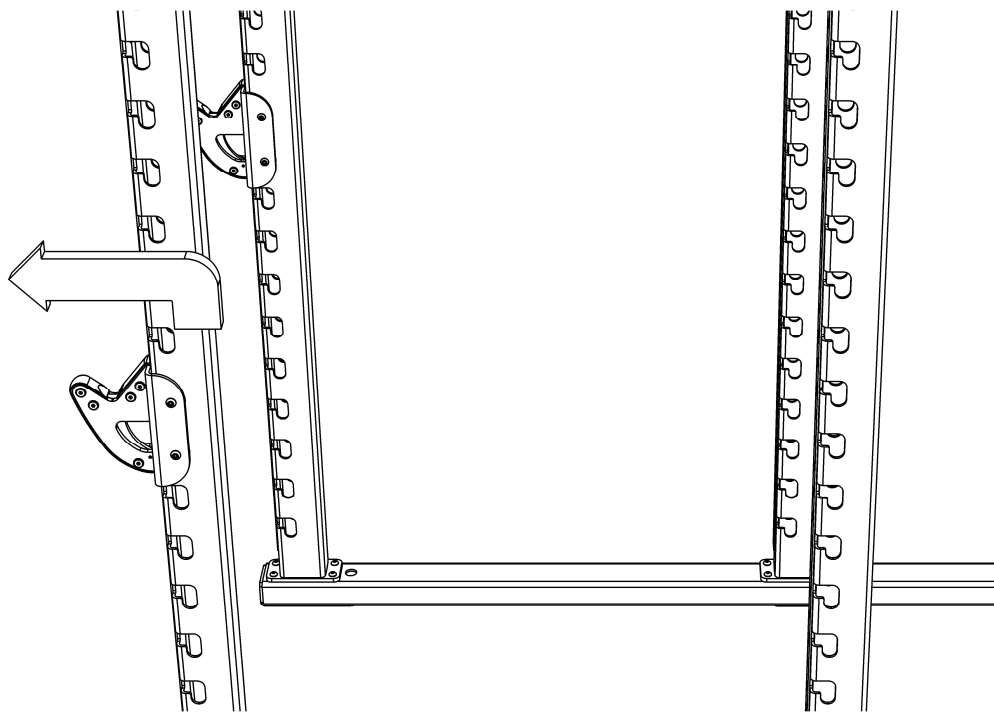

To remove or reposition the hooks, squeeze the handle / trigger and lift them up then out.

MAINTENANCE



WARNING!

READ AND UNDERSTAND ALL MAINTENANCE PROCEDURES.

Failure to follow all procedures listed below may cause serious injury and/or decrease equipment functionality.

- Frequently check to see that all bolts are securely fastened.
- Frequently check to see that weight equipment is functioning properly.
- Touch up paint may be used to cover scratches or blemishes sustained through use.
- A silicone based lubricant may be used on moving parts to maintain proper function.
- Mild detergent or disinfectant may be used to clean weight equipment.
- Replace any damaged equipment with genuine Rogers Athletic parts. Failure to do so may result in unsafe equipment and/or personal injury.

CUSTOMER SERVICE

For parts or service contact Rogers Athletic Company. When ordering parts be sure to provide all relevant information available including the name and part number of the equipment purchased. This information is located on the cover of this product information package. Customer service hours are Monday through Friday from 8:00 a.m. to 5:00 p.m. Eastern Standard Time. Customers can phone (989) 386-2950 or toll free at (800) 457-5337. Fax toll free at (888) 549-9659 or mail to:

Rogers Athletic Company
3760 W. Ludington Drive
Farwell, MI 48622

Rogers Athletic Company
3760 N. Ludington Drive
Farwell, MI 48622
www.rogersathletic.com
(989) 386-2950
(800) 457-5337
Fax toll free (888) 549-9659

PIP410706