



ROGGEERS
For the Perfection of Football Fundamentals™

PRODUCT INFORMATION PACKET

PRODUCT NAME: TRAP CHUTE

PRODUCT PART NUMBER: 410415, 410420
410425 & 410430

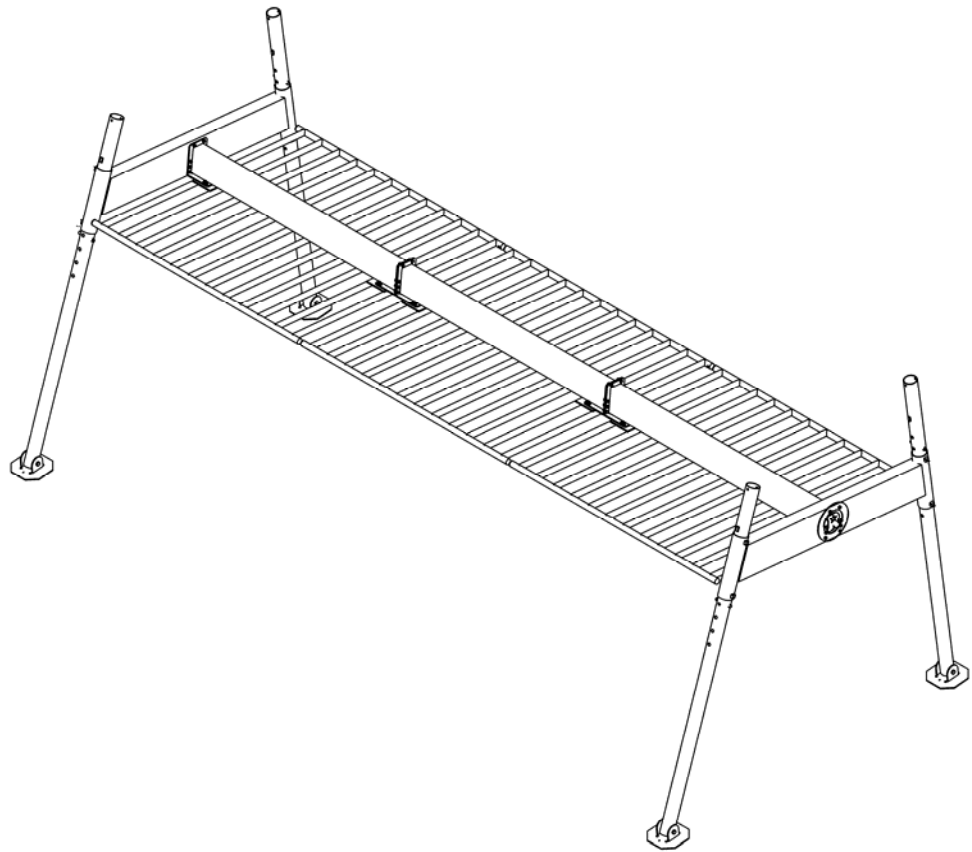

KEEP INFORMATION PACKET FOR FUTURE REFERENCE

TABLE OF CONTENTS

- Introduction.....1
- General Safety Rules.....2
- Symbols.....3
- Technical Specifications.....4
- Assembly Instructions.....5
- Maintenance.....7
- Customer Service Information.....7

INTRODUCTION

The Rogers Athletic Trap Chute has been designed and manufactured with safety, performance and dependability as top priorities, making it easy to operate and maintain.

The care you give your Trap Chute will greatly determine your satisfaction with its performance and service life. Careful study of this manual is encouraged to obtain a thorough understanding of your new Trap Chute and its functions and maintenance.

If your manual becomes lost or destroyed, Rogers Athletic will gladly provide you with a new copy. Should you require additional information or assistance, please feel free to contact us at 1-800-457-5337.

BECAUSE ROGERS ATHLETIC MAINTAINS AN ONGOING PROGRAM OF
PRODUCT DEVELOPMENT AND IMPROVEMENT, WE RESERVE THE RIGHT
TO MAKE IMPROVEMENTS IN DESIGN OR CHANGES IN SPECIFICATIONS
WITHOUT INCURRING ANY OBLIGATIONS TO INSTALL THEM ON UNITS
PREVIOUSLY SOLD.

GENERAL SAFETY RULES



WARNING!





READ AND UNDERSTAND ALL INSTRUCTIONS.

Failure to follow all instructions listed below may result in serious personal injury.

SAVE THESE INSTRUCTIONS

- **Read the Product Information Packet.** Failure to read the information packet is considered a misuse of this equipment.
- **Inspect equipment prior to use. DO NOT use if it appears damaged or inoperable.**
- **Obtain a medical exam prior to beginning any new physical activity.** Use equipment only if properly fit to engage in physical activity.
- **Stop physical activity if you feel faint, dizzy, or experience pain at any time and consult your physician.**
- **Use field equipment in a supervised environment.**
- **Keep body and clothing clear of all moving parts**
- **Stay clear of all pinch points.**
- **Become familiar with all caution and warning decals affixed to the field equipment before use.**
- **Never cover or deface caution/warning labels.**
- **Save these instructions.** Refer to them frequently and use them to instruct others who may use the Trap Chute. If you loan someone your Trap Chute, loan them these instructions also.
- **Do not climb on Trap Chute.**

SYMBOLS

	<p>Safety Alert: Precautions that involve your safety.</p>
 <div data-bbox="380 533 591 701" style="border: 1px solid black; padding: 5px;"> <p>⚠ WARNING</p> <p>Pinch Point. Keep hands and fingers clear.</p> </div>	<p>Pinch Point Symbol: Failure to keep hands away from pinch points may result in personal injury.</p>
 <div data-bbox="380 802 591 970" style="border: 1px solid black; padding: 5px;"> <p>⚠ WARNING</p> <p>Read and understand operator's manual and all other safety instructions before using this equipment.</p> </div>	<p>Read the Operator's Manual: To reduce risk of injury, user must read and understand operator's manual before using this product.</p>
 <div data-bbox="380 1062 591 1230" style="border: 1px solid black; padding: 5px;"> <p>⚠ WARNING</p> <p>Avoid Injury. Do not climb.</p> </div>	<p>Do Not Climb Warning Label: To reduce risk of injury, do not climb field equipment.</p>

ROGERS ATHLETIC TRAP CHUTE SPECIFICATIONS

TRAP CHUTE (PART # 410415, 410420, 410425, 410430)

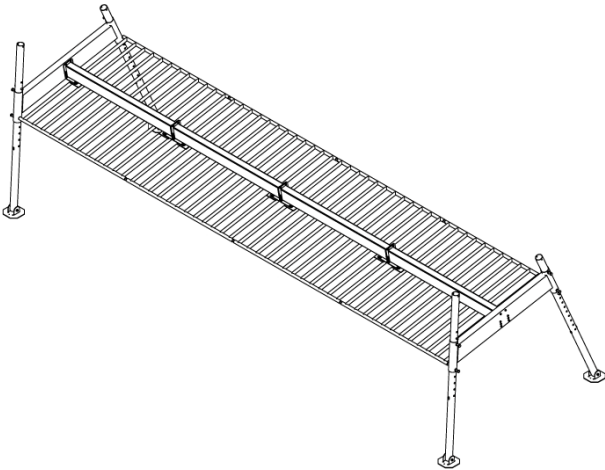

Weight:	15' = 544 lbs (247 kg)
	20' = 644 lbs (292 kg)
	25' = 744 lbs (337 kg)
	30' = 844 lbs (383 kg)
Lengths:	15', 20', 25', or 30"
Width:	5'
Height:	max 65", min 43"

- Free to move laterally, but limited in height, keeps players low to evade detection.
- Change the height and the angle of the chute to best develop your players' skills.
 - Height adjusts 22" in 3" increments from 43" to 65"
 - Angle adjusts from 0 to 16 degrees
 - Self-leveling feet keep the Trap Chute planted at all times.
- Design drills that go the entire length of the Trap Chute, exiting through the legs.
- Run tight formations with the entire offensive line and the wide receivers through the 25' or 30' model.
- Powder-coated steel protects your investment.
- Optional Castor Kit allows the Trap Chute to be moved so grass wears evenly or for different drills.

Trap Chute Construction, Finish, and Hardware

- Constructed of ASTM specified steel.
- Baked-on powder coat finish.
- Zinc-plated hardware.

ASSEMBLY INSTRUCTIONS

1

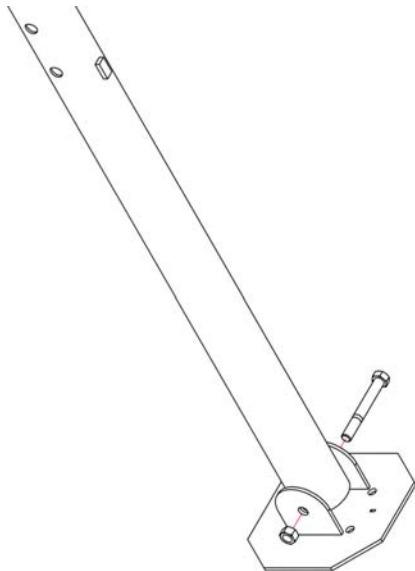

Attach Foot Pads to Trap Chute Legs using (4) $\frac{1}{2}$ " x 4" bolts and (4) $\frac{1}{2}$ " nuts.

2

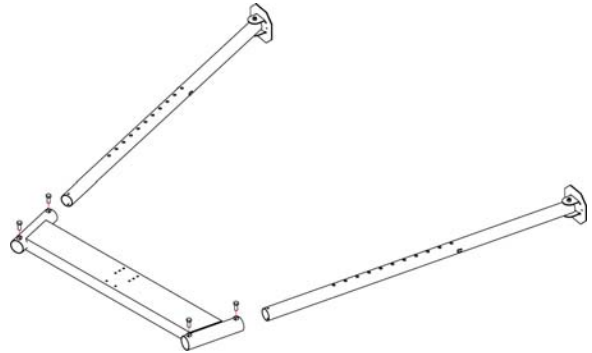

With the Trap Chute End Frame(s) on the ground, insert legs as shown, until the End Frame rests on the leg's stops. Repeat for second End Frame (set aside until step 5)

3

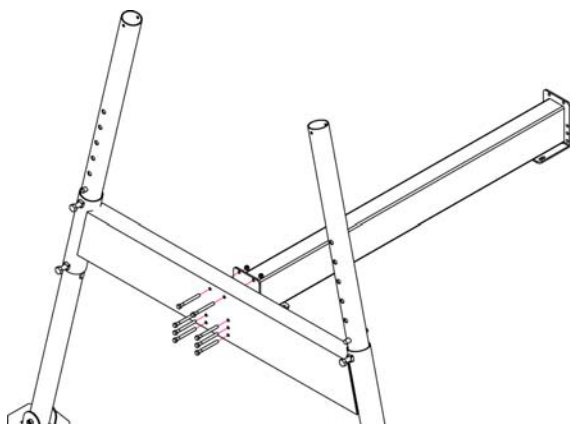

First stand End Frame up. Using (8) $\frac{3}{8}$ " x $3\frac{3}{4}$ " bolts and (8) $\frac{3}{8}$ " nuts, fasten the Trap Chute Top Tube to the End Frame. Leave bolts loose and let the Top Tube rest on the ground for the next step.

4

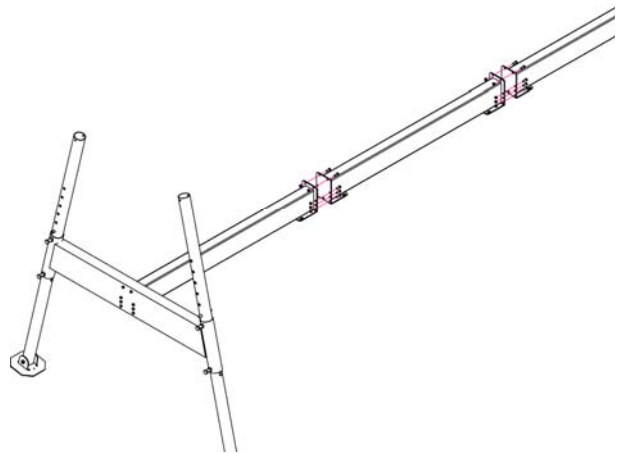

Attach the remaining Top Tubes to each other with (8) $\frac{3}{8}$ " x 1" bolts and (8) $\frac{3}{8}$ " nuts per tube.

5

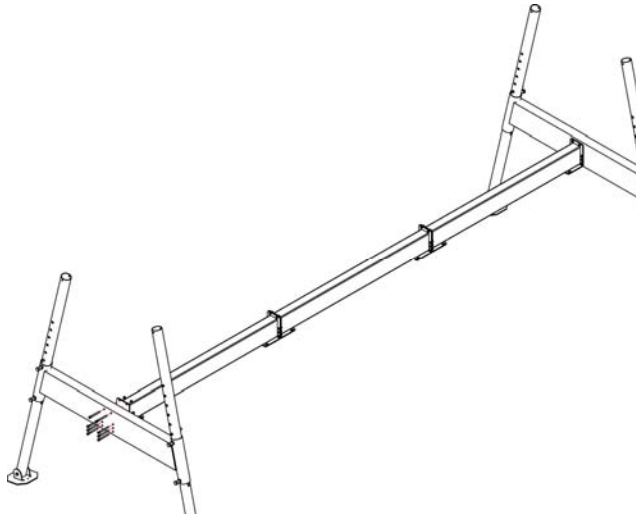

Note: Steps 5 & 6 require at least 2 people.

Using (8) 3/8" x 3 3/4" bolts and (8) 3/8" nuts, attach the End Frame assembly to the chain of Top Tubes. Tighten all bolts left loose.

6

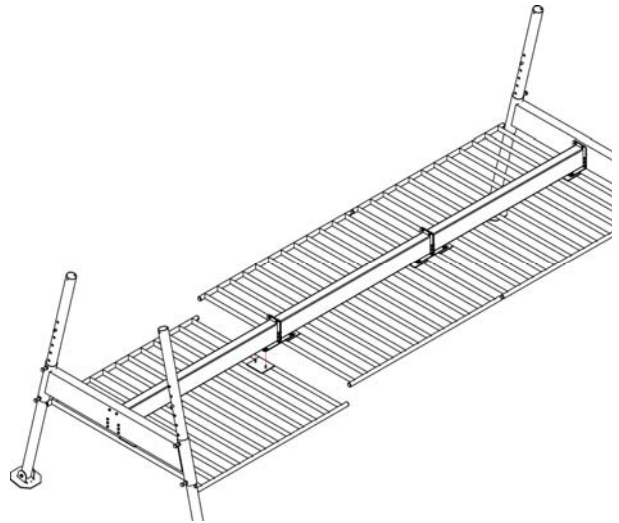

Attach the Trap Chute Top Frames to the Top Tubes with (4) 3/8" x 1" bolts and (4) 3/8" nuts per frame.

CUSTOMER SERVICE

For parts or service contact Rogers Athletic Company. When ordering parts be sure to provide all relevant information available including the name and part number of the equipment purchased. This information is located on the cover of this product information package. Customer service hours are Monday through Friday from 8:00 a.m. to 5:00 p.m. Eastern Standard Time. Customers can phone (989) 386-2950 or toll free at (800) 457-5337. Fax toll free at (888) 549-9659 or mail to:

Rogers Athletic Company
3760 W. Ludington Drive
Farwell, MI 48622

MAINTENANCE



WARNING!

READ AND UNDERSTAND ALL MAINTENANCE PROCEDURES.

Failure to follow all procedures listed below may cause serious injury and/or a decrease in equipment functionality.

- **Frequently check to see that all bolts are securely fastened.**
- **Touch up paint may be used to cover scratches or blemishes sustained through use.**
- **Field equipment should be washed periodically with soapy water to maintain original surface finish.**
- **A silicone based lubricant may be used on moving parts to maintain proper function.**
- **Replace any damaged equipment with genuine Rogers Athletic parts.** Failure to do so may result in unsafe equipment and/or personal injury.

Rogers Athletic Company
3760 N. Ludington Drive
Farwell, MI 48622
www.rogersathletic.com
(989) 386-2950
(800) 457-5337
Fax toll free (888) 549-9659